

# KOMATSU

## WA475-10

*EU Stage V Engine*

**WHEEL LOADER**



# WA475

**ENGINE POWER**

217 kW / 291 HP @ 1.600 rpm

**OPERATING WEIGHT**

25.110 - 27.760 kg

**BUCKET CAPACITY**

4,2 - 4,9 m<sup>3</sup>

# Walk-Around

WA475-10



**ENGINE POWER**

217 kW / 291 HP @ 1.600 rpm

**OPERATING WEIGHT**

25.110 - 27.760 kg

**BUCKET CAPACITY**

4,2 - 4,9 m<sup>3</sup>



## OVERWHELMING PERFORMANCE. THE NEXT GENERATION LOADER.

### *Powerful and Environmentally Friendly*

- EU Stage V engine
- Komatsu Hydraulic Mechanical Transmission (K-HMT)
- Massive reduction in fuel consumption & emissions
- 15% higher engine torque, at lower rpm

### *First-Class Comfort*

- Completely redesigned cab
- Tinted UV-protection glass
- High-performance air conditioning
- New monitoring system

### *Maximised Efficiency*

- High efficiency buckets
- Komatsu traction control system (K-TCS)
- Massive lifting power and break-out force
- High precision steering

### *State-of-the-Art Controls*

- Independent control of driveline and work equipment
- Auto hill-holding function
- Travel speed control dial

### *Easy Maintenance*

- Tilttable one-piece engine hood
- Wide core radiator with auto reverse fan
- Factory fitted automatic lubrication system

### *KOMTRAX*

- Komatsu Wireless Monitoring System
- 4G mobile communications
- Integrated communication antenna
- Increased operational data and fuel savings



A maintenance program  
for Komatsu customers

# Powerful and Environmentally Friendly



## **Komatsu Hydraulic Mechanical Transmission (K-HMT)**

K-HMT combines the benefits of hydrostatic and mechanical powertrains. This innovative technology, developed by Komatsu, provides extra power to the WA475-10, along with ultra-low fuel consumption and industry-leading productivity. An electronic controller works to maintain the engine speed low and constant. Minimum interaction is required, and operations are easier.

## **Increased engine power**

The engine is specifically designed to work together with K-HMT technology. It develops a higher performance and provides up to 15% more engine torque at lower engine speeds, compared to the previous model.

## **Massive lifting force**

The Z-bar linkage is optimised for significantly quicker loading cycles. More lifting power and higher break-out forces make bucket filling easier. In combination with the new Komatsu high-efficiency buckets, this provides significantly increased production rates, with more tonnes-per-hour.

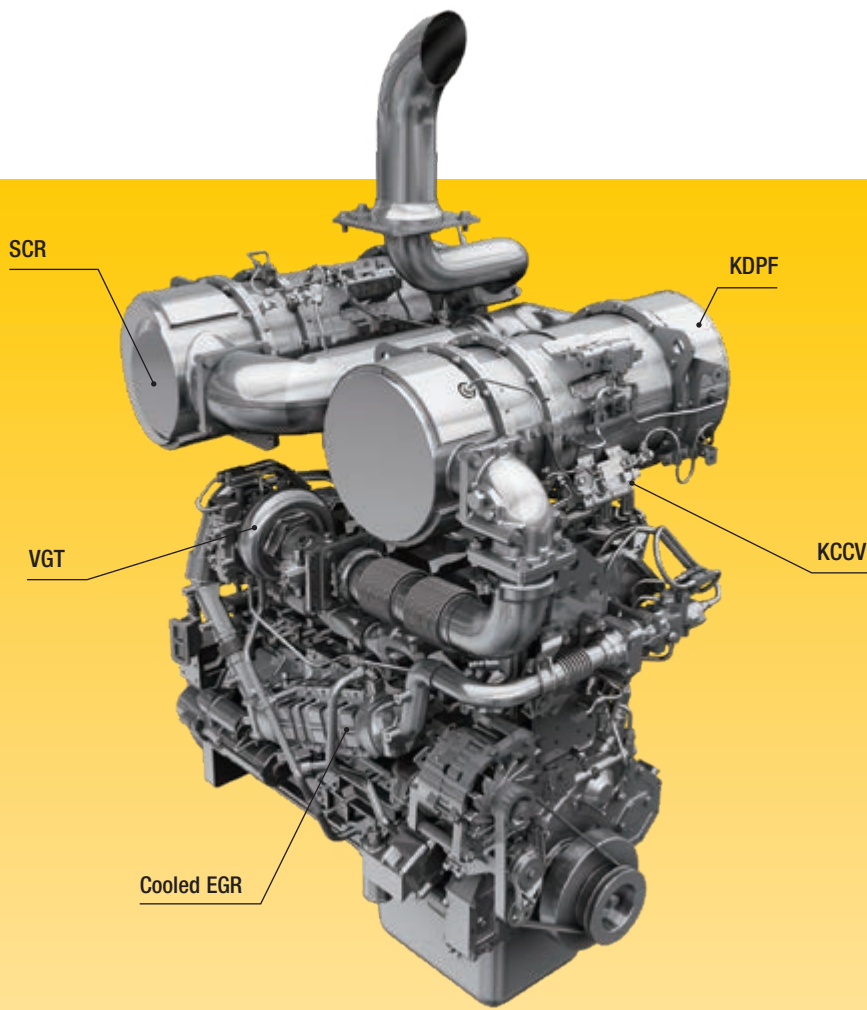
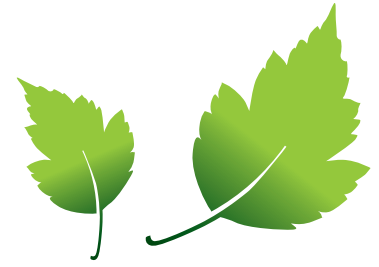

### Komatsu EU Stage V

The Komatsu EU Stage V engine is productive, dependable and efficient. With ultra-low emissions, it provides a lower environmental impact and a superior performance to help reduce operating costs and lets the operator work in complete peace of mind.

### Heavy-duty aftertreatment

The aftertreatment system combines a Komatsu Diesel Particulate Filter (KDPF) and Selective Catalytic Reduction (SCR). The SCR injects the correct amount of AdBlue® into the system at the proper rate to break down NOx into water (H<sub>2</sub>O) and non-toxic nitrogen gas (N<sub>2</sub>). NOx emissions are reduced by 80% vs. EU Stage IIIB engines.

#### Exhaust Gas Recirculation (EGR)

Cooled EGR is a technology well-proven in current Komatsu engines. The increased capacity of the EGR cooler now ensures very low NOx emissions and a better engine performance.

#### Komatsu Closed Crankcase Ventilation (KCCV)

Crankcase emissions (blow-by gas) are passed through a CCV filter. The oil mist trapped in the filter is returned back to the crankcase while the filtered gas is returned to the air intake.

#### High-Pressure Common Rail (HPCR)

To achieve complete fuel burn and lower exhaust emissions, the heavy-duty High-Pressure Common Rail fuel injection system is computer controlled to deliver a precise quantity of pressurised fuel into the redesigned engine combustion chamber by multiple injections.

#### Variable Geometry Turbo (VGT)

The VGT provides optimal airflow to the engine combustion chamber under all speed and load conditions. Exhaust gas is cleaner, fuel economy is improved while machine power and performance are maintained.

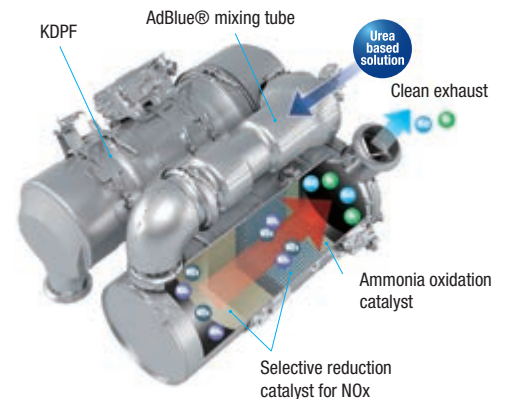

Adjustable idle shutdown automatically turns off the engine after it idles for a set period of time



Low engine speed matching provides more power and less fuel consumption, as the engine always operates at optimum speed



Eco-gauge and an Eco guidance with active recommendations help maximising fuel savings

# Maximised Efficiency

## Independent control of driveline and work equipment

This revolutionary system eases operations and enables shorter V-shape cycles. Boom speed is now controlled with the hydraulic lever and not by the accelerator pedal. The right balance between traction and boom lifting speed can easily be found and the WA475-10 can smoothly approach the loading area.

## Travel speed control dial

Machine speed can be kept constant thanks to the integrated travel speed control dial, with no need to apply the brake even when travelling downhill.

## Automatic digging system

The automatic digging system actuates the bucket tilt and lifting operations by detecting the sensing pressure applied to the work equipment. The system adapts to different types of material with no human intervention required. Operator fatigue is greatly reduced and ideal load capacity ensured.

## High precision steering

The re-designed steering system is more powerful and accurate. This eases Load & Carry operations on rough terrain and enhances the smooth controllability of the machine.

## Komatsu traction control system (K-TCS)

K-TCS controls the K-HMT and the engine to optimise traction automatically depending on work conditions. The provided rim pull can be set to 4 different levels to prevent wheels from spinning, regardless of ground conditions. Constant traction increases productivity and reduces tire wear and costs.

## Drive line with automatic braking function

The WA475-10 has an automatic engine brake that helps to slow down the machine smoothly when the operator takes a foot off the accelerator. It also reduces brake wear. In addition, the new auto hill-holding function makes it very easy to operate on a slope.



WA475-10



# First-Class Comfort



## Newly designed cab: unrivalled operator convenience

The all-new Komatsu SpaceCab™ on the Komatsu “Dash 10” wheel loaders features more comfort and visibility, making these models a dream to operate. Entering and exiting the WA475-10 is facilitated by angled steps, large handrails and rear hinged doors with a wide opening angle. A standard second door further eases egress and communications on the jobsite. High visibility and ergonomic controls help

to maximise the operator’s productivity. The lever console features a new command-selector dial and is adjustable on five axes to suit any operator. A slightly increased internal air pressure prevents dust and other particulates from entering the cab.

## Perfect all-round visibility

A bay style window, a large curved front screen and floor-to-ceiling glass surfaces contribute to all-round visibility. All glass surfaces are tinted and feature a UV radiation filter to minimise the heat caused by the sun.

## State-of-the-Art Controls



### New, fully air-suspended operator station

The wide spacious cab features a new, fully air-suspended operator seat that includes the side consoles mounted together with a high back, fully adjustable, standard heated seat for improved comfort. A seat ventilation is optionally available to maximise comfort.

### “By Wire” operating

The Electronic Pilot Control (EPC) lever console is integrated with the seat and can be easily adjusted to suit any operator. The short levers are fingertip controlled for precise and fatigue-free operating, with a no-vibration modulating function for slowing and stopping a lowering bucket. The upper and lower boom cut-out position can be pre-set with a switch.

### New monitoring system and controls

All operational switches are illuminated and centralised on the front pillar and in optimum reach of the operator. The rear-view monitor is height adjustable to match the operator's requirements.

### EPC multifunction lever (option)

The EPC multifunction lever with an integrated forward/reverse switch allows the simplest and most comfortable operation of the equipment. With one hand the driver can simultaneously control the attachment and switch between forward and reverse. The multifunction lever is the perfect choice for earthmoving jobs.

### Komatsu Short Lever Steering (K-SLS) (option)

The new finger-type joystick steering allows more accurate steering by the operator who can now sit relaxed in the new air-suspended and fully adjustable seat to control the machine with no big effort needed for frequent steering. Less fatigue and work in a perfectly adapted operating position will improve concentration and the quality and efficiency of the work.



Newly designed controls. The command selector switch (1) allows convenient navigation through the monitor menus, as in a passenger car. The new travel speed control dial (2) keeps the machine's speed constant when travelling downhill.



Komatsu Short Lever Steering (K-SLS) (option)

# Information & Communication Technology



## Lower operating costs

Komatsu ICT contributes to the reduction of operating costs by assisting to comfortably and efficiently manage operations. It raises the level of customer satisfaction and the competitive edge of our products.

## Large TFT colour monitor

Info displayed "at a glance" on the central dashboard. A 7-inch, full color, high-resolution monitor provides key machine metrics including KDPF status and data for AdBlue® level and fuel consumption, and the setting of the machine's travel speed.

## Eco guidance

Messages from the Eco guidance system are displayed in real-time during operations and on the exit screen when the ignition is turned off. The Eco guidance menu enables the operator to check operation logs and fuel consumption. These records are useful to reduce overall fuel usage and can be saved and sorted by the operator.



"At a glance" information on the central dashboard



A multifunction monitor displays and controls a wealth of operational and maintenance information



Fuel consumption history display

# KOMTRAX

## The way to higher productivity

KOMTRAX uses the latest wireless monitoring technology. Compatible on PC, smartphone or tablet, it delivers insightful and cost saving information about your fleet and equipment, and offers a wealth of information to facilitate peak machine performance. By creating a tightly integrated web of support it allows proactive and preventive maintenance and helps to efficiently run a business.



## Knowledge

You get quick answers to basic and critical questions about your machines – what they're doing, when they did it, where they're located, how they can be used more efficiently and when they need to be serviced. Performance data is relayed by wireless communication technology (satellite, GPRS or 4G depending on model) from the machine to a computer and to the local Komatsu distributor – who's readily available for expert analysis and feedback.

## Power

The detailed information that KOMTRAX puts at your fingertips 24 hours a day, 7 days a week gives the power to make better daily and long-term strategic decisions – at no extra cost. Problems can be anticipated, maintenance schedules customised, downtime minimised and machines kept where they belong: working on the jobsite.

## Convenience

KOMTRAX enables convenient fleet management on the web, wherever you are. Data is analysed and packaged specifically for effortless and intuitive viewing in maps, lists, graphs and charts. You can foresee eventual maintenance issues and required spare parts, and troubleshoot a problem before Komatsu technicians arrive on site.



# Easy Maintenance



## Excellent serviceability

A powered tilting hood provides full access to the engine compartment. Side doors give quick and convenient access for daily checks and service. Full rear fenders are standard, a gauge on the AdBlue® fill cap minimises overfilling. Servicing costs are remarkably reduced, which provides a lower lifecycle cost.



## Wide core radiator with auto reverse fan

A wide core radiator prevents clogging even when working in a dusty environment. To minimise manual cleaning, a reversible fan blows dust out, automatically or on demand. The “automatic reverse” function allows to set the cleaning length and the time between cleaning to adjust perfectly to the working conditions.



## Factory fitted automatic lubrication system

The automatic lubrication system reduces the daily service work to the absolute minimum. Robust piping ensures consistent lubrication and operating reliability, and significantly increases the machine’s service life. The system is electronically monitored and features a signal light in the cabin.

## Komatsu CARE™

Komatsu CARE™ is a maintenance program that comes as standard with your new Komatsu machine. It covers factory-scheduled maintenance, performed with Komatsu Genuine parts by Komatsu-trained technicians. Depending on your machine’s engine, it also offers extended coverage of the Komatsu Diesel Particulate Filter (KDPF) or the Komatsu Diesel Oxidation Catalyst (KDOC), and of the Selective Catalytic Reduction (SCR). Please contact your local Komatsu distributor for terms and conditions.



## Equipment Management and Monitoring System (EMMS)

The large high resolution monitor panel displays various machine information and allows for multiple settings. The “Operation Records” menu shows records of the average fuel consumption, idling hours, and other features. Abnormality codes are clearly displayed and stored to alert you and simplify troubleshooting. The monitor also provides for advanced monitoring of the system parameters through the service mode to aid in troubleshooting and reduce downtime.

## Diesel particulate filter regeneration

No interruption or extension of daily work is required to regenerate the diesel particulate filter system. Due to its superior Komatsu technology, KDPF regeneration takes place automatically, at any time.



WA475-10



Well located service doors allow convenient and safe access to daily service points



Basic maintenance screen



Aftertreatment device regeneration screen for the KDPF



# Tailored Solutions



## Working gear division

Komatsu wheel loaders combined with a wide range of genuine Komatsu attachments provide the perfect solution for any industry sector. For special applications our “Working Gear” division offers purpose-built machines and attachments. The tailor made solutions allow high performance and outstanding reliability even under toughest conditions.

## Waste & Recycling

Renowned for high quality standards and reliability, Komatsu meets the huge demand placed on machines by the waste management industry with a wide range of options and modifications available ex factory for our base machines. This provides the flexibility to adapt the Komatsu wheel loader range to the specific requirements of different waste handling applications and jobsite conditions. Whether you choose the full waste specification or individual components, you’re guaranteed increased machine performance, availability and efficiency.

## Salt & Chemical

A corrosive environment is one of the toughest challenges for any machine. Upgraded with a special coating on the metal parts and with various optional modifications to fit the application at hand, Komatsu “Salt & Chemical” configured wheel loaders hold up even under the most aggressive conditions. Reduced downtime, less maintenance and repair costs and a long lifetime: Komatsu machines perform as well and last as long as in a non-corrosive environment.

WA475-10

# Komatsu Quality & Safety

## Designed and built by Komatsu

The engine, hydraulics, power train, front and rear axles are original Komatsu components. All these components are subject to the highest quality standards right down to the smallest screw. All components are fully co-ordinated with one another, thus offering the maximum efficiency and reliability.

## Heavy-duty axles

The heavy-duty axles allow exceptional service life even under the toughest working conditions. The optional limited slip differentials are most suitable for soft and slippery ground like sand or wet soil.

## Robust torsion-resistant main frame

The frame design with hinge points far apart guarantees the high stability for the overall construction and reduces bearing stress in the torsional ranges.



## Optimal jobsite safety

Safety features on the Komatsu WA475-10 comply with the latest industry standards and work in synergy to minimise risks to people in and around the machine. The greatly improved visibility, along with a seat belt caution indicator and back-up alarm increase jobsite safety. Ser-rated steps, wide catwalks and large handrails allow safe and easy access to the cab and to maintenance check points.



Front cleaning step for safe and easy access to the front window



Full LED lighting for improved visibility

# Buckets and Attachments

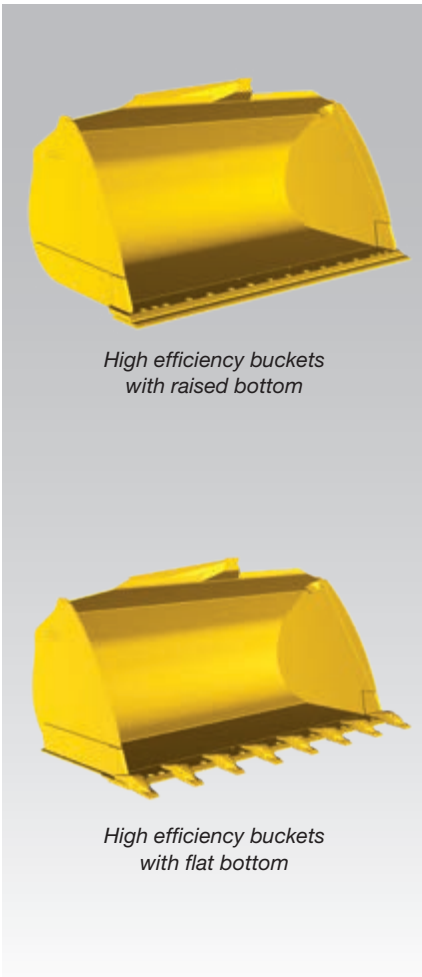

*High efficiency buckets with raised bottom*

*High efficiency buckets with flat bottom*

## New high efficiency bucket range

The new Komatsu buckets enable easier bucket fill and significantly higher fill factors, contributing to more efficiency and less fuel consumption. They feature a longer bottom allowing for more content, a wider opening for an easier fill and a new rear shape that enables material to flow easily into the bucket. Their rounded sides give them a higher fill factor, and an integrated spill guard protects the bucket linkage. Flush screws (with BOC) reduce resistance when filling and keep material from clogging when dumping.

## High dump buckets

For maximum dumping heights with light materials like coal or woodchips. The dump cylinders are located either inside or outside the bucket.

## Hydraulic quick-coupler

The WA475-10 can change attachments in a matter of seconds with the HD hydraulic quick-coupler, available as optional equipment.

# Specifications

## ENGINE

Model	Komatsu SAA6D125E-7
Type	Common rail direct injection, water-cooled, emissionised, turbocharged, after-cooled diesel
Engine power	
at rated engine speed	1.600 rpm
ISO 14396	217 kW / 291 HP
Max. torque / engine speed	1.560 Nm / 1.330 rpm
No. of cylinders	6
Bore × stroke	125 × 150 mm
Displacement	11,04 l
Fan drive type	Hydraulic, reversible
Alternator	90 A / 24 V
Starter motor	11 kW / 24 V
Filter	Main-flow filter with water separator
Air filter type	Dry-air filter with automatic dust emission and preliminary purification including a dust display
Fuel	Diesel fuel, conforming to EN590 Class 2/Grade D. Paraffinic fuel capability (HVO, GTL, BTL), conforming to EN 15940:2016

## TRANSMISSION

Type	Komatsu Hydraulic Mechanical Transmission (K-HMT)	
Max. travel speeds (forwards/backwards) (tyres 26.5 R25)		
1. speed range	1-8 km/h	1-8 km/h
2. speed range	14 km/h	14 km/h
3. speed range	24 km/h	28 km/h
4. speed range	38 km/h	-

## CHASSIS AND TYRES

System	4-wheel drive	
Front axle	Komatsu HD axle, semi-floating (LSD-differential optional)	
Rear axle	Komatsu HD axle, semi-floating, 26° swing angle (LSD-differential optional)	
Differential	Spiral bevel gear pair	
Final drive	Planetary gear in an oil bath	
Tyres	26.5 R25	

## SERVICE REFILL CAPACITIES

Fuel tank	380 l
Engine oil	38 l
Hydraulic system	135 l
Cooling system	65 l
Front axle	59 l
Rear axle	59 l
Transmission case	40 l
AdBlue® tank	36 l

## BRAKES

Operating brakes	Hydraulically actuated, wet multi-disc brakes on all wheels
Parking brake	Wet multi-disc
Emergency brake	Uses the parking brake

## HYDRAULIC SYSTEM

Type	Komatsu CLSS (Closed Centre Load Sensing System)
Hydraulic pump	Variable piston pump
Working pressure	360 kg/cm <sup>2</sup>
Maximum pump flow	306 l/min
No. of hydraulic/bucket cylinders	2/1
Type	Double-action
Bore diameter × stroke	
Boom cylinder	150 × 764 mm
Bucket cylinder	180 × 540 mm
Hydraulic cycle with rated load bucket filling	
Raise time	5,8 s
Lowering time (empty)	3,1 s
Dumping time	1,6 s

## STEERING SYSTEM

System	Articulated frame steering
Type	Completely hydraulic power steering
Steering angle to either side	40°
Steering pump	Variable piston pump
Working pressure	250 kg/cm <sup>2</sup>
Pumping capacity	145 l/min
No. of steering cylinders	2
Type	Double-action
Bore diameter × stroke	95 × 441 mm
Smallest turn (outer edge of the tyre 26.5 R25)	6.265 mm

## CABIN

Two-door SpaceCab™ in conformity with ISO 3471 with ROPS (roll over protective structure) in conformity with SAE J1040c and FOPS (falling object protective structure) in conformity with ISO 3449. The air-conditioned pressurised cabin is mounted upon hydrobearings and is noise dampened.

## ENVIRONMENT

Engine emissions	Fully complies with EU Stage V exhaust emission regulations
Noise levels	
LwA external	107 dB(A) (2000/14/EC Stage II)
LpA operator ear	70 dB(A) (ISO 6396 dynamic test)
Vibration levels (EN 12096:1997)	
Hand/arm	≤ 2,5 m/s <sup>2</sup> (uncertainty K = 2,31 m/s <sup>2</sup> )
Body	≤ 0,5 m/s <sup>2</sup> (uncertainty K = 0,58 m/s <sup>2</sup> )
Contains fluorinated greenhouse gas HFC-134a (GWP 1430). Quantity of gas 1,1 kg, CO <sub>2</sub> equivalent 1,57 t.	

# Dimensions & Performance Figures

## MEASUREMENTS AND WORKING SPECIFICATIONS

Bucket type		Bucket with raised bottom		Bucket with raised bottom		Bucket with raised bottom	
		w. teeth	w. BOC	w. teeth	w. BOC	w. teeth	w. BOC
Bucket capacity (heaped, ISO 7546)	m <sup>3</sup>	<b>4,5</b>	<b>4,7</b>	<b>4,5</b>	<b>4,7</b>	<b>4,7</b>	<b>4,9</b>
Sales code		C76	C77	C86	C87	C82	C83
Material density	t/m <sup>3</sup>	1,8	1,7	1,8	1,7	1,7	1,6
Bucket weight	kg	2.255	2.290	2.240	2.285	2.315	2.365
Static tipping load, straight	kg	20.070	19.900	20.180	19.985	20.010	19.820
Static tipping load, 40° articulated	kg	17.355	17.195	17.450	17.275	17.295	17.120
Break-out force hydraulic	kN	198	189	209	198	198	189
Lifting capability hydr. at ground level	kN	240	238	243	239	240	237
Operating weight	kg	25.670	25.705	25.655	25.704	25.730	25.780
Turning radius at corner of tyres	mm	6.265	6.265	6.265	6.265	6.265	6.265
Turning radius at bucket edge	mm	7.080	7.020	7.125	7.070	7.155	7.095
a Reach at 45°	mm	1.590	1.445	1.530	1.390	1.590	1.445
b Dumping height at 45°	mm	2.760	2.885	2.815	2.940	2.760	2.885
c Hinge pin height	mm	4.345	4.345	4.345	4.345	4.345	4.345
d Height top edge of bucket	mm	6.090	6.090	6.030	6.030	6.090	6.090
e Digging depth	mm	150	180	150	180	150	180
f Max. loading height at 45°	mm	4.030	4.030	4.030	4.030	4.030	4.030
A Overall length, bucket grounded	mm	9.610	9.445	9.535	9.365	9.610	9.445
B Wheel base	mm	3.450	3.450	3.450	3.450	3.450	3.450
C Bucket width	mm	2.990	2.990	3.160	3.170	3.160	3.170
D Width over tyres	mm	2.990	2.990	2.990	2.990	2.990	2.990
E Track width	mm	2.240	2.240	2.250	2.250	2.245	2.245
F Ground clearance	mm	500	500	500	500	500	500
H Overall height	mm	3.480	3.480	3.480	3.480	3.480	3.480

All measurements with tyres 26.5 R25 (L3 with -25 mm offset) and additional counterweight (A15).  
 Details of dumping heights and reach to cutting edge or bolt-on cutting edge (BOC) or teeth.

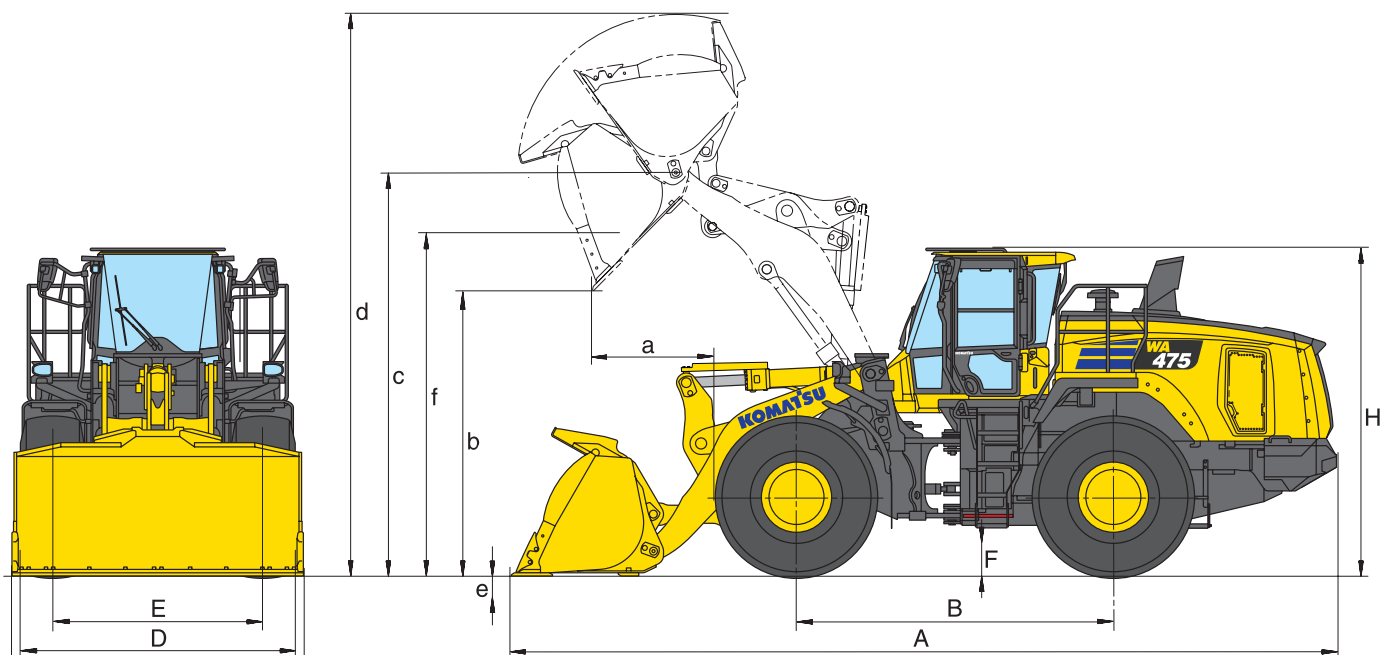

WA475-10

Bucket with flat bottom		Bucket with flat bottom		High-lift equipment
w. teeth	w. BOC	w. teeth	w. BOC	(Change in data)
4,2	4,4	4,5	4,7	-
C52	C53	C32	C33	-
1,9	1,8	1,8	1,7	-0,2
2.280	2.320	2.355	2.395	-
20.100	19.920	19.940	19.770	-3.215
17.380	17.215	17.230	17.070	-2.940
209	198	198	189	-
243	239	240	237	-44
25.695	25.735	25.770	25.810	+910
6.265	6.265	6.265	6.265	-
7.055	7.000	7.080	7.020	+287
1.530	1.390	1.590	1.445	+175
2.815	2.940	2.760	2.885	+510
4.345	4.345	4.345	4.345	+510
6.030	6.030	6.090	6.090	+510
150	180	150	180	+140
4.030	4.030	4.030	4.030	+480
9.535	9.365	9.610	9.445	+600
3.450	3.450	3.450	3.450	-
2.990	2.990	2.990	2.990	-
2.990	2.990	2.990	2.990	-
2.245	2.245	2.240	2.245	-
500	500	500	500	-
3.480	3.480	3.480	3.480	-

TYPICAL MATERIAL DENSITY – LOOSE (in kg/m³)

Basalt	1.960
Bauxite, Kaolin	1.420
Earth, dry, ex store	1.510
Earth, wet, excavated	1.600
Gypsum, broken	1.810
Gypsum, crushed	1.600
Granite, broken	1.660
Limestone, broken	1.540
Limestone, crushed	1.540
Gravel, unscreened	1.930
Gravel, dry	1.510
Gravel, dry, 6-50 mm	1.690
Gravel, wet, 6-50 mm	2.020
Sand, dry, loose	1.420
Sand, damp	1.690
Sand, wet	1.840
Sand and clay, loose	1.600
Sand and gravel, dry	1.720
Sandstone	1.510
Slate	1.250
Slag, broken	1.750
Stone, crushed	1.600
Clay, natural	1.660
Clay, dry	1.480
Clay, wet	1.660
Clay and gravel, dry	1.420
Clay and gravel, wet	1.540

CHANGE IN DATA CAUSED BY:

		Heavy counterweight (A25)	Without add. counterweight (A05)	Tyres 26.5 R25 L4	Tyres 26.5 R25 XMINE L5	Tyres 775/65 R29 L3
Operating weight	kg	+641	-545	+368	+1040	+655
Static tipping load, straight	kg	+1.455	-1.280	+310	+790	+465
Static tipping load, 40° articulated	kg	+1.215	-1.070	+275	+695	+410
Overall length	mm	-	-175	±0	±0	±0
Reach at 45°	mm	-	-175	-10	-35	+2
Dump height at 45°	mm	-	-	+16	+45	+3
Width over tyres	mm	-	-	±0	+60	+116
Overall height	mm	-	-	+16	+45	+3

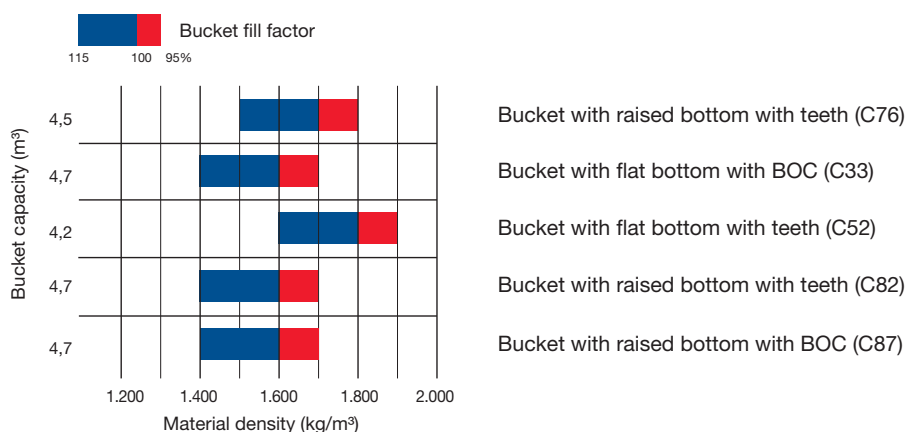

# Standard and Optional Equipment

## ENGINE

Komatsu SAA6D125E-7 turbocharged common rail direct injection diesel engine	●
EU Stage V compliant	●
Komatsu Diesel Particulate Filter (KDPF)	●
Selective Catalytic Reduction (SCR)	●
Engine mode selection system	●
Komatsu SmartLoader Logic	●
Adjustable idle shutdown	●
Fuel filter with water separator	●
Batteries 2 × 180 Ah / 2 × 12 V	●

## CHASSIS AND TYRES

Heavy-duty axles	●
Front fenders	●
Full rear fenders	●
Limited-slip differential (LSD) front and rear	○
Tyres 26.5 R25 L3, L4, L5	○
Tyres 775/65 R29	○

## HYDRAULIC SYSTEM

Independent control of driveline and work equipment	●
2-spool main control valve	●
EPC fingertip control, two levers, including:	
- Bucket stop modulation	●
- Boom stop pre-setting	●
- Automatic dig function	●
Automatic return-to-dig	●
3-spool main control valve	○
EPC fingertip control, three levers	○
EPC 1-lever (multifunction lever) with sliding proportional control for attachments	○
Biodegradable oil for hydraulic system	○

## TRANSMISSION AND BRAKES

Komatsu Hydraulic Mechanical Transmission (K-HMT)	●
Komatsu traction control system (K-TCS)	●
Combined brake and inching pedal	●
Axle oil cooling system	○

## CABIN

Spacious double door driver's cab to DIN/ISO	●
ROPS/FOPS frame according to SAE/ISO	●
Heated, high back air suspension seat, console mounted height adjustable arm rests	●
Retractable seat belt	●
Automatic climate control system	●
Multifunction video compatible colour monitor with Equipment Management and Monitoring System (EMMS) and efficiency guidance	●
DAB+ digital radio w. auxiliary input (MP3 jack)	●
Heated rear window	●
Rear window wiper	●
Adjustable steering column	●
2× 12 V power supply	●
Auto hill-holding function	●
Heated, high back air suspension seats with pneumatically adjustable lumbar support, console mounted height adjustable arm rests	○
4-point seat belt	○
Sun roller blind	○
Komatsu Short Lever Steering (K-SLS)	○

## LIGHTING SYSTEM

2 LED main headlights	●
2 LED working lights at front and rear	●
Reversing light	●
Additional lights at front and rear	○
4 LED working lights at front and rear	○

## SERVICE AND MAINTENANCE

Hydrostat-driven radiator fan with automatic reversing function	●
Wide core side-by-side radiator	●
KOMTRAX – Komatsu wireless monitoring system (4G)	●
Komatsu CARE™ – a maintenance program for Komatsu customers	●
Tool-set	●
Automatic central lubrication	●
Filling tool for central lubrication system	○
Turbo II air pre-cleaner, cyclone type	○

## SAFETY EQUIPMENT

Emergency steering system	●
Vandalism protection	●
Back-up alarm	●
Battery main switch	●
Handrails on left/right	●
Rear-view mirror, heated and remote controlled	●
Rear-view camera system	●
Fire extinguisher	○
Beacon (LED)	○
Roof rail	○
Optical back-up alarm (strobe light)	○

## ATTACHMENTS

Hydraulic quick-coupler	○
High efficiency buckets with flat or raised bottom	○
High-dump buckets	○
Fork carrier and tines	○
Waste handling buckets	○
Light material buckets	○

## OTHER EQUIPMENT

Counterweight (A05)	●
Electronically controlled load stabilizer (ECSS II)	●
High-lift equipment w. add. counterweight	○
Special custom colour	○
Additional counterweight (A15)	○
Heavy counterweight (A25)	○
Anti-corrosion specification	○
Waste-handler specification	○
Cold area kit (engine and cab pre-heating)	○

Further equipment on request

- standard equipment
- optional equipment

Your Komatsu partner:

# KOMATSU

**Komatsu Europe  
International N.V.**

Mechelsesteenweg 586  
B-1800 VILVOORDE (BELGIUM)  
Tel. +32-2-255 24 11  
Fax +32-2-252 19 81  
[www.komatsu.eu](http://www.komatsu.eu)

VENSS07004 10/2020

**KOMATSU** is a trademark of Komatsu Ltd. Japan.