



GOVONI

Specialty Automotive Tools

www.govoni.it

GARAGE EQUIPMENT & SPECIALTY AUTOMOTIVE TOOLS - EXPORT CATALOGUE 07 2008

INDEX

Alfa Romeo	01
BMW	06
Fiat	09
Ford	18
GM - Opel - Chevrolet	22
Lancia	24
Mazda	27
Peugeot - Citroen	28
Renault - Nissan	31
Suzuki	37
Volvo	38
VW - Audi - Seat - Skoda	40
Engine - Valves	48
Springs & Shock Absorbers	55
Lifters	58
Hubs and Bearings	59
Brake Service Tools	66
Headlight Testers	67
Oil Sump & Filters	69
Injector Tools	75
Glow Plug Tools	81
Tools for General Repairs	82
Steering System	87
Body Tools	88
Tyres	93
Motorbike	96

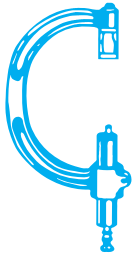

GOVONI
Specialty Automotive Tools
www.govoni.it



GARAGE EQUIPMENT & SPECIALTY AUTOMOTIVE TOOLS



ISTITUTO DI CERTIFICAZIONE DELLA QUALITÀ
www.certiquality.it

CERTIFICATO n. **5649**
CERTIFICATE No

SI CERTIFICA CHE L'ORGANIZZAZIONE
WE HEREBY CERTIFY THAT THE ORGANIZATION

GO.VO.NI SRL

I - 41100 MODENA (MO) - VIA GIARDINI 25

NELLE SEGUENTI UNITA' OPERATIVE / IN THE FOLLOWING OPERATIVE UNITS

I - 40014 CREVALCORE (BO) - VIA DEGLI ORSI 97

HA ATTUATO E MANTIENE UN SISTEMA DI GESTIONE QUALITÀ CHE È CONFORME ALLA NORMA
HAS IMPLEMENTED AND MAINTAINS A QUALITY MANAGEMENT SYSTEM WHICH COMPLIES WITH THE FOLLOWING STANDARD

UNI EN ISO 9001:2000

PER LE SEGUENTI ATTIVITÀ / FOR THE FOLLOWING ACTIVITIES

SETTORE
CODE **EA 18**

GUARANTEE AND PRODUCTS INSURANCE :

ALL OUR PRODUCTS ARE COVERED BY A LIABILITY INSURANCE AGAINST ACCIDENTS TO PEOPLE OR THINGS EXTENDED BY A MAJOR EUROPEAN COMPANY, FOR 516.457 EURO. ALL OUR PRODUCTS ARE GUARANTEED AGAINST MANUFACTURING DEFECTS FOR ONE YEAR



OFFICES AND WAREHOUSE:

Via degli Orsi, n. 97 - 40014 Loc. Beni Comunali - Crevalcore (BO) Italy

Tel: +39.051.982688 - Tel: +39.051.980798 - Fax: +39.051.6801371

E-mail: info@govoni.it - www.govoni.it



HISTORY

Our company starts in the late '60 with the production of a special tool used to compress and dismount engine valves resorts: this tool, with the necessary modification, is manufactured until present time and forms part of the Govoni Company logo. In few years, the line was expanded with special tools for the automotive business, several times under specification of the customers, big European buying groups and vehicle manufacturers, both for the production process and for the after-sale service. With a functional and efficient structure, our Company can develop in a relatively short time new equipments and tools, also under customer specifications. We wish to underline that within our customers we count the major European vehicle manufacturers.



GOVONI STAFF

Our aim is to reach always new markets, placing our products. We work constantly on the research and development field in order to study, realize and improve new items accordingly to the market's demands. All GOVONI staff works in accordance to the Quality System with the goal to satisfy our customers' needs that represent our primary source and well-being.

LO STAFF GOVONI

Nostro obiettivo è quello di coprire un mercato sempre più vasto, ricercando nuove nicchie per la collocazione dei nostri prodotti. Agiremo con determinazione sul fronte della ricerca e dello sviluppo, molla necessaria perché possano essere studiati prodotti nuovi e possano essere migliorati i prodotti già in essere. Sfrutteremo le metodologie che ormai da anni la gestione della Qualità ci ha suggerito e ce ne serviremo per far sì che tutto il nostro staff possa lavorare teso all'univoco desiderio della piena soddisfazione dei nostri clienti che sono la fonte primaria della nostra attività e del nostro benessere aziendale.



PRODUCTION

Nowadays Quality System has become essential and vital for all the companies to compete against competitors. For that reason all GOVONI production runs follow procedures aimed to guarantee the total control and supervision of the production. This policy allows to monitor the production from the arrival of raw material to the packaging and the delivery of the finished product to our customers.



PRODUZIONE

Oggi è divenuto essenziale per la competitività di tutte le aziende puntare sulla qualità. La GOVONI anche per questo motivo realizza al suo interno l'intero ciclo produttivo, che viene gestito con procedure mirate a garantire un controllo totale dei processi. Questa politica di produzione permette di monitorare il processo dall'entrata della materia grezza fino al confezionamento e alla spedizione del prodotto finito al cliente.





WAREHOUSES

The warehouses of raw material, semimanufactured and finished product are constantly replenished by the production department. Thanks to this management and well organized production we can grant brief delivery times satisfying our customers' needs.

MAGAZZINI

I magazzini, materia prima, prodotto semilavorato e prodotto finito, sono continuamente riforniti dal reparto produzione. Questa gestione ci consente di avere tempi di consegna più brevi, di dare una risposta pronta alle esigenze del cliente, ed una programmazione meglio organizzata.



Timing tools



310 119 000

Complete set for timing on Alfa Romeo petrol engines 1.4 - 1.6 - 1.8 - 2.0 lts.

Cassetta fasatura motori Alfa Romeo 1.4 - 1.6 - 1.8 - 2.0 benzina.

100A-100S (2nd & 3rd) cylinder:

Models:

Alfa 156 1600 16v

Alfa 145/146 1400 e 1600

Alfa 155 1600 16v - with and without phase variator.

105A-105S (2nd & 3rd) cylinder

Models:

Alfa 156 1800-2000 16v

Spider e Gtv TS 2000

155 TS 1800

Codes:

162.01, 321.04, 322.01, 323.01, 323.10, 335.03 341.03, 372.03, 671.06, 672.04 & 676.01



Timing tools



310 010 000

Complete set for timing on Alfa Romeo 1.6 eco 105 Hp petrol engines.

Cassetta fasatura motori Alfa Romeo 1.6 eco 105 cv. benzina.

130A-130S (2nd & 3rd) cylinder:

Models:

Alfa 147 1.6 ECO 105 hp.

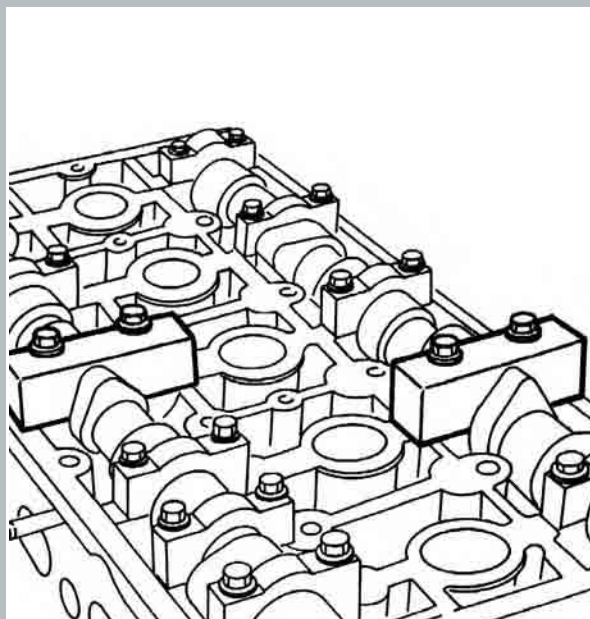

310 012 001

Complete set for timing on Alfa Romeo 3.0 V6 petrol engines.

Kit fasatura motori Alfa Romeo 3.0 litri V6 benzina.

30A-30S (1st aspiration right & 1st exhaust right) cylinder
31A-31S (6th aspiration left & 4th exhaust left) cylinder

Models:

Alfa 155 3.0 V6 engine
Alfa 166 3.0 V6 engine
Alfa GTV 3.0 V6 engine

Codes:

161.02, 161.05, 324.01, 324.05, 342.01, 343.01

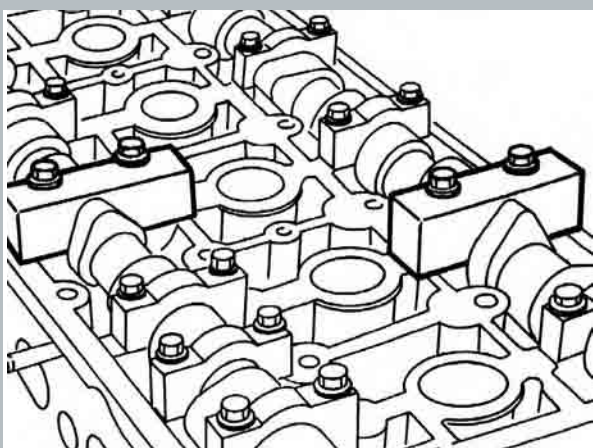

Timing tools



310 107 000

Complete set of timing tools suitable for 16v. diesel engines.

Cassetta fasatura per motori diesel 16v.

Models:

Alfa 145, 146, 147, 156, 159, 166, GT, Crosswagon Q4
Fiat Punto, Grande Punto, Bravo/Brava, Marea, Weekend, Stylo, Doblò/Cargo, Multipla, Idea, Panda
Lancia Ypsilon, Musa, Lybra, Thesys
Opel Corsa, Agila, Meriva, Combo Tour, Astra, Zafira, Vectra
Suzuki Ignis, Swift, Vagon R+, Grand Vitara, Crossover

Engines:

1.3 Multijet 16V, 1.3 Multijet CDTI, 1.3 DDiS 16V.
1.9-2.4 JTD Multijet, 1.9 CDTI, 1.9 DDiS

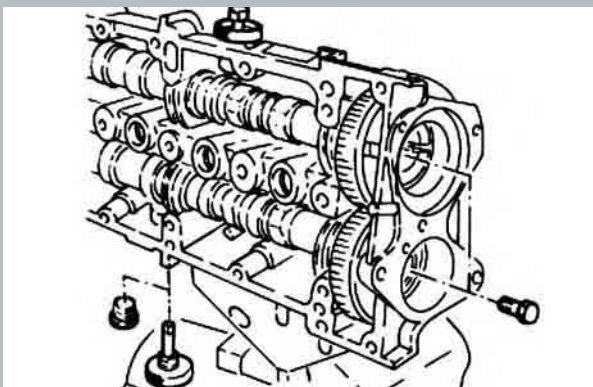

Timing tools



Timing tools



310 074 000

Set of tools for crankshaft timing on new 1.9-2.4 JTD Multijet 140Hp-175Hp, Alfa, Fiat, Lancia engines.

Cassetta fasatura nuovi 1.9-2.4 JTD Multijet 140cv-175cv, motori Alfa, Fiat, Lancia.

Models:

Alfa145, 146, 147, 156, 1.9 JTD 16V., 156 2.4 JTD 20V., 166 2.4 JTD 20V., GT 2.4 JTD 20V.

Fiat Punto, Grande Punto, Brava/Bravo Marea, Weekend, Stilo, Doblo/Cargo, Multipla 1.9 JTD 16V.

Lancia Lybra 1.9 JTD 16V., Lybra 2.4 JTD 20V., Thesys 2.4 JTD 20V.

Engines: 1.9-2.4 JTD

Codes:

323.02,371.01, 182B4.000, 182B9.000, 186A6.000, 188A2.000, 188A7.000, 188B2.000, 192A1.000, 192A3.000, 937A2.000, 939A1.000, 192A5.000, 192B1.000, 937A5.000, 939A2.000, 325.01, 342.02,362.02, 185A6.000, 841C.000, 841G.000,939A3.000

Timing tools



310 008 000

25 pieces set for gasoline timing 1.4 => 3.0 Alfa-Fiat-Lancia.

Cassetta 25 pezzi messa in fase motori benzina Alfa-Fiat-Lancia 1.4 => 3.0.

ART	CAM	CYL N.	ENGINE	N. Pcs
00	A	2	Bravo/Brava- Lancia Y10 1,4 12v.	1
10	A	3	Lancia K 5 cil. 2.0 20v. VIS engine from 1996	2
10	S	2		
20	A	1	Alfa 3.0 V6 24v.	2
20	S	1		
21	A	6		2
21	S	4		
40	A	3	Lancia 5 cyl. before '96	2
40	S	2		
50	A	2	Fiat Bravo/Brava/Marea - Lancia 1800 16v 115 HP - Delta/Dedra 1800 16v - 1860 847/C/2	2
50	S	3		
60	A	2	Fiat Coupé - Lancia - Alfa 1800 16v 130 HP - Alfa 155	2
60	S	3		
70	A	3	Fiat Bravo/Brava/Marea 2.0 20v	2
70	S	2		
80	A	2	Barchetta/Coupé 1.8 16v variator	2
80	S	3		
90	A	2	Alfa 145/146 1400 16v - 1600 16v (Step A engine only) - Alfa 147 1.6 120HP.	2
90	S	3		
100	A	2	Alfa 156 1600 16v - Alfa 145/146 1400 e 1600 - Alfa 155 1600 16v - with and without variator	2
100	S	3		
105	A	2	Alfa 156 1800-2000 16v - Spider e Gtv TS 2000 - 155 TS 1800	2
105	S	3		
120	A	3	Fiat 2.0 Turbo - Lancia 2.0 Turbo	2
120	S	2		

310 127 000

Complete set for timing on Alfa Romeo 2.0 JTS 165 hp.

Cassetta per la fasatura dei motori Alfa Romeo 2.0 JTS 165 cv.

150A-150S (2nd & 3rd) cylinder:

Models:

GT 2.0 JTS

Codes: 937A1.000, 932A2.000

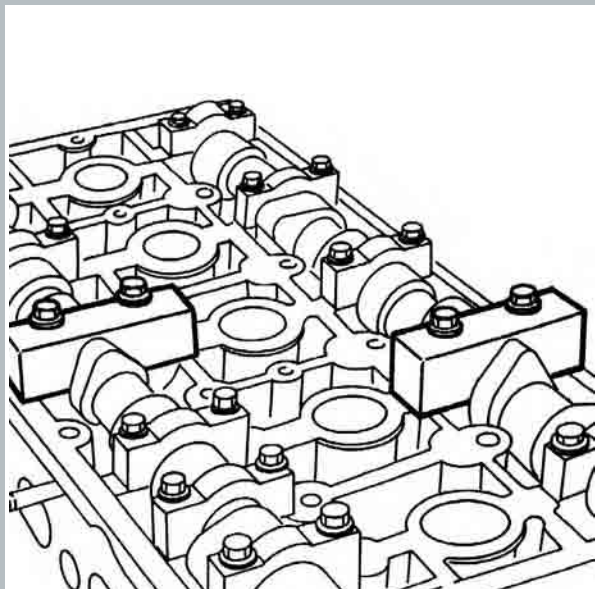
**Timing tools****310 095 000**

Complete set for timing on Alfa Romeo petrol engines 1.4 - 1.6 - 1.8 - 2.0 lts.

Cassetta fasatura motori Alfa Romeo 1.4 - 1.6 - 1.8 - 2.0 benzina.

100A-100S (2nd & 3rd) cylinder:

Models:

Alfa 156 1600 16v

Alfa 145/146 1400 e 1600

Alfa 155 1600 16v - with and without phase variator

105A-105S (2nd & 3rd) cylinder

Models:

Alfa 156 1800-2000 16v

Spider e Gtv TS 2000

155 TS 1800

Codes:

162.01, 321.04, 322.01, 323.01, 323.10, 335.03 341.03, 372.03, 671.06, 672.04 & 676.01

**Timing tools**



Special tools

313 023 000

Tools for dismounting phase alternator on Fiat, Alfa, Lancia.
Chiave frontale per smontaggio del variatore di fase, motori Fiat, Alfa, Lancia.

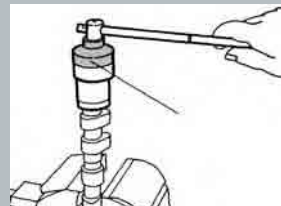

Special tools

313 063 000

Special tool for countershaft removal, suitable for Alfa engines.

Attrezzo speciale per smontaggio del contralbero di bilanciamento motore, modelli Alfa.



Special tools

313 151 000

Corteco introducer for the camshaft on Alfa 147, Fiat Stilo 1.9 JTD 16v.

Attrezzo introduttore "Corteco" per albero distribuzione Alfa 147, Fiat Stilo 1.9 JTD 16v.



Special tools

313 152 000

Locker for crankshaft pulley on motore Fiat 1.7, 1.8, 2.0, 2.0 turbo, 2.4 TD, 2.5, 3.0.

Attrezzo per il bloccaggio della puleggia albero motore Fiat 1.7, 1.8, 2.0, 2.0 turbo, 2.4 TD, 2.5, 3.0.

310 120 000

Timing tool M42, M50 gasoline engines
E34: 518, 520, 525 - E34 (VANOS) - E36: 316, 318, 320, 325.

Attrezzo messa in fase Bmw - M42, M50 BMW.

Models:

BMW Petrol: 316i/Compact (E30 1.6/E36/E46), 318i E30 E36 E46) 518i (E34), & Z3 1.8/1.9i(88-04)

Codes: M40 (Belt), M43 (Chain), 318tds/Compact (E36), 318iS (E30), 318iS Coupe Compact (E36), 318Ti Compact (E36), 320i, 323i, 325i, 328i (E36), 520i (E34/E39), 523i (E39), 525i (E34), 528i (E39), 728i (E38) & Z3 1.9/2.8i (89-98)

Codes: M42, M44, M50 & M52 (Chain)

BMW Diesel: 325td/tds (E36), 525td/tds (E34/E39), 725tds (E38) (91-03)

Rover:

Diesel 2.5 td/tds
Range Rover (94-02), 2.5 td/tds

Opel - Vauxhall:

Omega 2.5 tds

Timing tools



310 121 000

BMW petrol Soch engines setting up tool model 2-M40,M43-E30: 316, 318 - E28: 518 - E36: 318is.

Attrezzi messa in fase BMW Tipo 2 - M40, M43.

Models:

316i/Compact (E30 1.6/E36/E46), 318i E30 E36 E46) 518i (E34), & Z3 1.8/1.9i(88-04)

Codes: M40 (Belt), M43 (Chain)

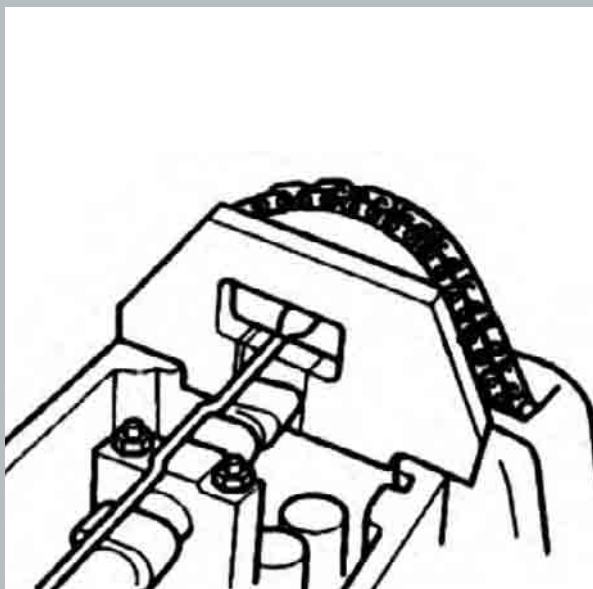

Timing tools

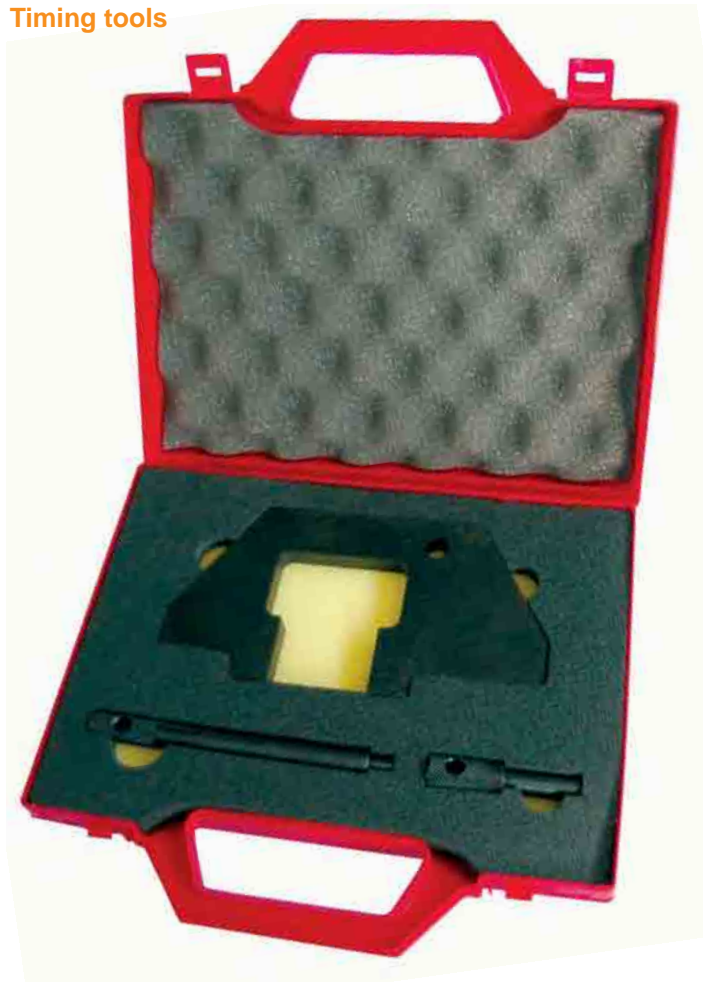

Timing tools



310 011 000

Complete timing set for BMW diesel and petrol, studied to place correctly camshaft and crankshaft during the replacement of timing belts.

Cassetta completa per la fasatura motori BMW Diesel e benzina, consente di posizionare correttamente sia l'albero a camme, sia l'albero motore durante la sostituzione della cinghia di distribuzione.

Models:

BMW petrol: 316i/Compact (E30 1.6/E36/E46), 318i E30 E36 E46) 518i (E34 VANOS), & Z3 1.8/1.9i(88-04)

Codes: M40 (Belt), M43 (Chain)

318tds/Compact (E36), 318iS (E30), 318iS Coupe Compact (E36), 318Ti Compact (E36), 320i, 323i, 325i, 328i (E36), 520i (E34/E39), 523i (E39), 525i (E34), 528i (E39), 728i (E38) & Z3 1.9/2.8i (89-98)

Codes: M42, M44, M50 & M52 (Chain)

PETROL SOCH ENGINES:

316i/Compact (E30 1.6/E36/E46), 318i E30 E36 E46) 518i (E34 VANOS), & Z3 1.8/1.9i(88-04)

Codes: M40 (Belt), M43 (Chain)

BMW diesel: 325td/tds (E36), 525td/tds (E34/E39), 725tds (E38) (91-03)

Rover: Diesel 2.5 td/tds

Range Rover: (94-02), 2.5 td/tds

Opel - Vauxhall: Omega 2.5 tds

Timing tools



310 061 000

Timing set for BMW 320d, 330d, 530d, 730d diesel engines.

Cassetta fasatura motori distribuzione BMW 320d, 330d, 530d, 730d.

Models: 320d, 330d (E46), 520d, 530d (E39)(98-04), 730d (E38)

Code: M47, M57 (Chain)

Suitable Also for:

Land Rover: Freelander (Td4)

MG-Rover: 75 2.0 CDT/CDTi (99-04)

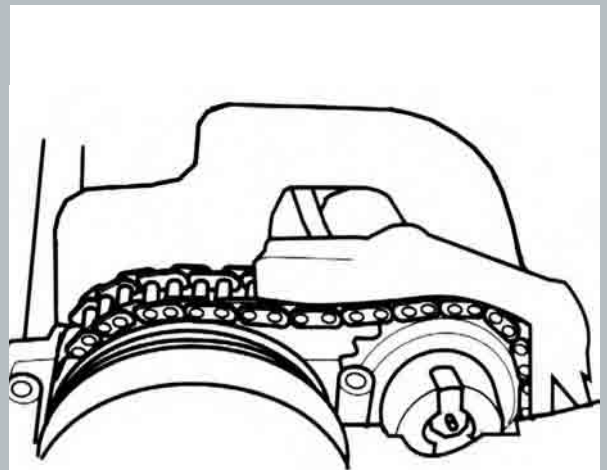

310 110 000

Complete set for timing suitable on BMW gasoline engines.

Cassetta completa per la fasatura dei motori benzina BMW.

Models:

318iS (E30), 318iS / Coup. / Compact (E36), 318Ti Compact (E36), 320i, 323i, 325i, 328i (E36)
Z3 1.9/2.0i/2.8i
520i(E34), 523i (E39), 525i(E34), 528i (E39), 530i/540i V8 (E34), 535i/540i(E39),
728i (E38) 730i/740i (E32), 730i/735i/740i (E38),
840i/840Ci (E31)
X3, X5 3.0i, X5 4.4i, X5 4.8is

Codes:

E30, E 31, E34, E36, E38, E39, M42, M44, M50 & M52, M62

Timing tools



313 155 000

Extractor for the water pump pulley on BMW engines.

INCLUDED:

313 155 003 Centring bush, size M 40x1,5 mm.
313 155 004 Centering bush, size M42X1,5 mm.

Attention:

Use together with mod. 313 155 000 during operations of injection pump removal.

Timing tools



313 155 003



313 155 004

Timing tools



310 002 000

Complete set for adjusting of fuel injection pump and locking the camshaft on Fiat diesel and turbo diesel engines.

Cassetta completa per la fasatura dei motori Fiat 1697 D-TD, 1929 D, 1929 TD.

Models: Punto, Fiorino, Palio Weekend, Ducato, Tempra, Tipo, Talento

Engines: 1.7 D, 1.7 TD, 1.9 D, 1.9 TD

Codes: 176A3.000, 176B3.000, 176A5.000, 146D7.000, 160A7.000, 336.01, 675.02.

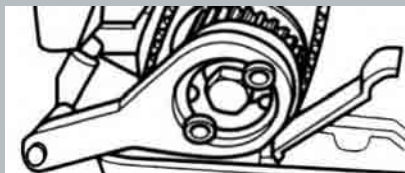

Timing tools



310 006 000

4 pieces set for Fiat Punto 1.2 and 1.4 16V.

Cassetta 4 pezzi messa in fase Fiat Punto 1.2 e 1.4 16V.

Models: Punto, Bravo, Brava, Marea, Palio Weekend, Stilo.

Engines: 1.2 16V, 1.4 16V.

Codes: 176B9.000, 182B2.000, 188A5.000, 843A1.000.



Timing tools



310 015 000

Timing kit for 1.6 16v gasoline engines mounted on Fiat vehicles.

Cassetta per la fasatura dei motori Fiat 1.6 16v benzina.

Models: Bravo, Brava, Marea, Palio Weekend, Stilo, Multipla.

Engines: 1.6 16V.

Codes: 178B3.000, 182A4.000, 182A6.000, 182B6.000.

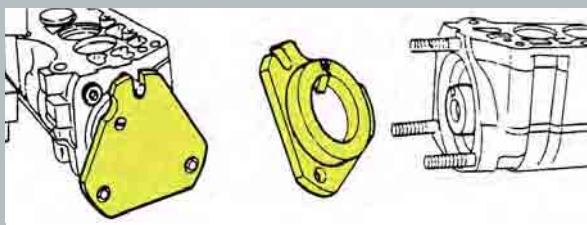

310 008 000

25 pieces set for gasoline timing 1.4 => 3.0 Alfa-Fiat-Lancia.

Cassetta 25 pezzi messa in fase motori benzina Alfa-Fiat-Lancia 1.4 => 3.0.

ART	CAM	CYL N.	ENGINE	N. Pcs
00	A	2	Bravo/Brava- Lancia Y10 1,4 12v.	1
10	A	3	Lancia K 5 cil. 2.0 20v. VIS engine from 1996	2
10	S	2		
20	A	1	Alfa 3.0 V6 24v.	2
20	S	1		
21	A	6		
21	S	4		
40	A	3	Lancia 5 cyl. before '96	2
40	S	2		
50	A	2	Fiat Bravo/Brava/Marea - Lancia 1800 16v 115 HP - Delta/Dedra 1800 16v - 1860 847/C2	2
50	S	3		
60	A	2	Fiat Coupé - Lancia - Alfa 1800 16v 130 HP - Alfa 155	2
60	S	3		
70	A	3	Fiat Bravo/Brava/Marea 2.0 20v	2
70	S	2		
80	A	2	Barchetta/Coupé 1.8 16v variator	2
80	S	3		
90	A	2	Alfa 145/146 1400 16v - 1600 16v (Step A engine only) - Alfa 147 1.6 120HP.	2
90	S	3		
100	A	2	Alfa 156 1600 16v - Alfa 145/146 1400 e 1600 - Alfa 155 1600 16v - with and without variator	2
100	S	3		
105	A	2	Alfa 156 1800-2000 16v - Spider e Gtv TS 2000 - 155 TS 1800	2
105	S	3		
120	A	3	Fiat 2.0 Turbo - Lancia 2.0 Turbo	2
120	S	2		

Timing tools



310 027 000

Timing tools for Fiat 2.4 gasoline engines: Stylo, Thesys.

Cassetta fasatura motori Fiat 2.4 benzina: Stylo, Thesys.

Models: Stylo, Thesys.

Engines: 2.4 20V.

Codes: 192A2.000.

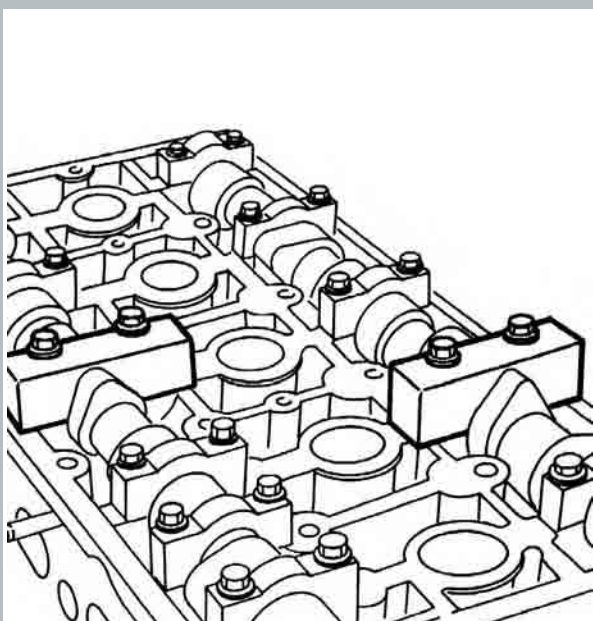

Timing tools



Timing tools

310 060 000

Set of tools for camshaft and crankshaft timing on Fiat Ducato 2.3 JTD diesel engines.

Cassetta fasatura motori - distribuzione Fiat Ducato 2.3 JTD.

Models: Ducato, Iveco, Daily.

Engines: 2.3 JTD.

Codes: F1AE048IC, F1CE048ID, F1AE048IA, F1AE048IB, F1CE0481A.

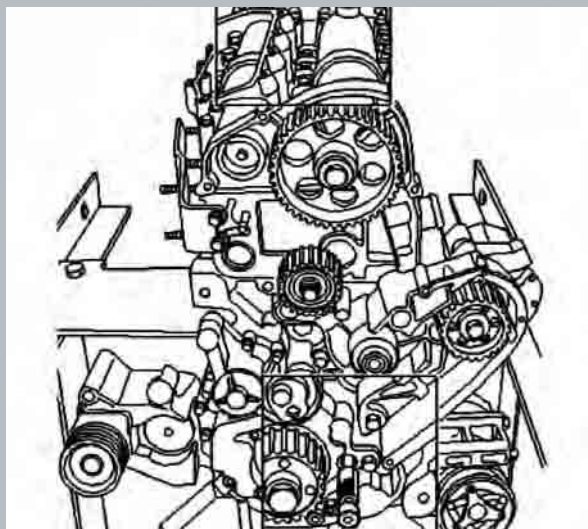

Timing tools

310 062 000

Extractor for Common Rail pump on Ducato and New Ducato 2300 JTD engines.

Attrezzo per lo smontaggio della pompa Common Rail motori Fiat Ducato e Nuovo Ducato 2300 JTD.

Models: Ducato, New Ducato.

Engines: 2.3 JTD.

Codes: F1AE048IC, F1CE048ID.



313 000 000

Set of tools for crankshaft timing on 1.9-2.4 JTD diesel Alfa-Fiat-Lancia engines.

Attrezzo adattabile per la messa in fase dei motori 1.9-2.4 JTD diesel Alfa-Fiat-Lancia.

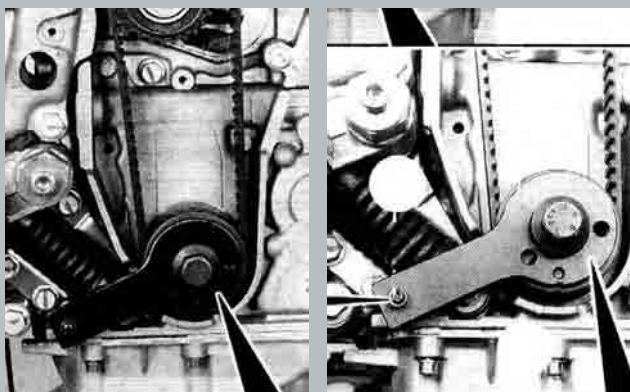
**Timing tools****310 074 000**

Set of tools for crankshaft and camshaft timing on new 1.9-2.4 Multijet 140-175 cv. Alfa-Fiat-Lancia engines.

Cassetta fasatura nuovi 1.9-2.4 jtd Multijet 140cv-175cv, motori Alfa-Fiat-Lancia.

Models:

Alfa Romeo: 145,146,147,156,159,166,GT

Fiat: Punto,Grande Punto,Brava/Bravo,Marea, Weekend, Stilo, Doblo/Cargo, Multipla

Engines: 1.9 JTD 8v., 1.9 JTD 16v., 2.4 JTD 10v., 2.4 JTD 20v.

Codes: 323.02,371.01, 182B4.000, 182B9.000,186A6.000, 188A2.000,188A7.000, 188B2.000, 192A1.000, 192A3.000, 937A2.000, 939A1.000, 192A5.000, 192B1.000, 37A5.000,939A2.000, 325.01, 342.02,362.02, 185A6.000, 841C.000, 841G.000,939A3.000

Timing tools**310 097 000**

Timing set for new Fiat 1.4, 1.4 16v Starjet, 1.4 16v. T-jet petrol.

Set completo di attrezzi fasatura per il nuovo motore Fiat 1.4, 1.4 16v Starjet, 1.4 16v T-jet benzina.

Models:

Fiat: Idea, Punto, Grande Punto, Stilo, Panda, 500, Bravo
Lancia: Ypsilon, Musa

Engines: 1400 Fire evo 2, 1400 16v. 95 HP. Starjet, 1400 16v. 100 HP. Starjet, 1400 16v. 90 HP. Starjet, 1400 16v. 120 HP. T-jet, 1400 16v. 150 HP. T-jet.

Timing tools



Timing tools

310 075 000

Set of tools for crankshaft and camshaft timing on new 1.3 Multijet 16V. Fiat, Lancia, Opel, Suzuki engines.

Cassetta fasatura nuovi motori 1.3 Multijet 16V. Fiat, Lancia, Opel, Suzuki.

Models: Punto, Panda, Idea, Doblo, Doblo Cargo, Stylo, Ypsilon, Musa, Corsa, Agila, Meriva, Combo Tour, Ignis, Swift, Vagon R+.

Engines: 1.3 Multijet, 1.3 CDTI, 1.3 DDiS.

Codes: 188A8.000, 188A9.000,

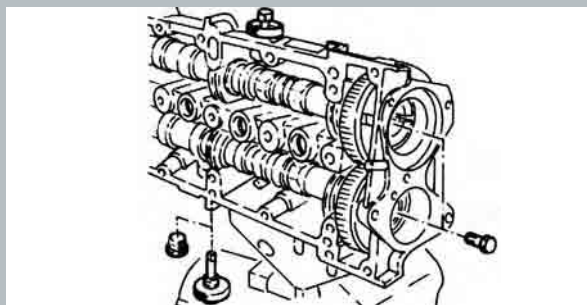

Timing tools

310 107 000

Set of tools for crankshaft and camshaft timing on new 1.3, 1.9, 2.4 Multijet 140-175 cv. Alfa-Fiat-Lancia, Opel, Suzuki engines.

Cassetta fasatura nuovi 1.9-2.4 jtd Multijet 140cv-175cv, motori Alfa-Fiat-Lancia.

Models:

Alfa Romeo: 145,146,147,156,159,166,GT

Fiat: Punto, Grande Punto, Panda, Idea, Brava, Bravo, Marea Weekend, Stilo, Doblo, Doblo Cargo, Multipla

Lancia: Ypsilon, Musa

Opel: Agila, Meriva

Suzuki: Combo Tour, Ignis, Swift, Vagon R+.

Engines: 1.3 Multijet, 1.3 CDTI, 1.3 DDiS., 1.9 CDTI, 1.9 JTD 8v., 1.9 JTD 16v., 2.4 JTD 10v., 2.4 JTD 20v.

Codes: 323.02,371.01, 182B4.000, 182B9.000,186A6.000, 188A2.000,188A7.000, 188A8.000, 188A9.000, 188B2.000, 192A1.000, 192A3.000, 937A2.000, 939A1.000, 192A5.000, 192B1.000, 37A5.000,939A2.000, 325.01, 342.02,362.02, 185A6.000, 841C.000, 841G.000,939A3.000

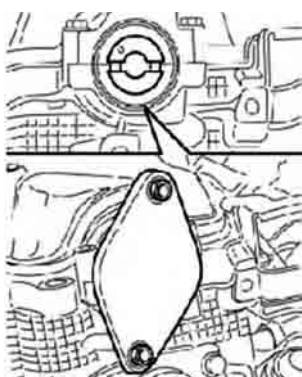

Timing tools

313 165 000

Special timing tool for new Fiat Panda 1.2 gasoline engines.

Attrezzo per la fasatura dei motori Nuova Fiat Panda 1.2 benzina.

Models: Punto, New Punto, New Panda

Engines: 1.2 8v.

Codes: 188 A4.000

310 131 000

Timing kit for 1.2-1.4-1.6 liters Fiat gasoline engines.

Cassetta per la fasatura dei motori Fiat 1.2-1.4-1.6 benzina.

Models: Punto, Bravo, Brava, Marea, Palio, Palio Weekend, Stilo, Multipla.

Engines: 1.2 16v, 1.4 12v, 1.4 16v, 1.6 16v.

Codes: 176B9.000, 182B2.000, 188A5.000, 843A1.000, 178B3.000, 182A4.000, 182A6.000, 182B6.000.

Timing tools



310 125 000

Timing kit for commercial vehicles mounting 2.2-2.3-3.0 multijet engines.

Cassetta per la fasatura dei motori multijet 2.2-2.3-3.0 montati su veicoli commerciali.

Models: Fiat new Ducato, Iveco Daily, Ford Transit Van, Peugeot Boxer, Citroen Jumper.

Engines: 2.2 JTD, 2.3 JTD, 3.0 JTD

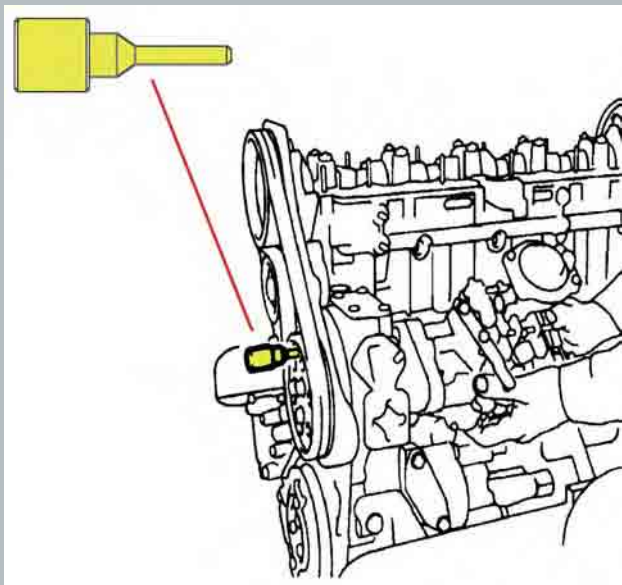

Timing tools





Special tools

313 023 000

Tools for dismounting phase alternator on Fiat, Alfa, Lancia.

Chiave frontale per smontaggio del variatore di fase, motori Fiat, Alfa, Lancia.

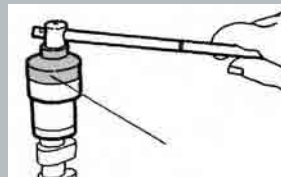

Special tools

313 026 000

Crankshaft locking tool for Fiat 1.4 12V. gasoline engine.

Staffa bloccaggio albero motore, modelli Fiat 1.4 12V.



Special tools

313 029 000

Special belt-stretcher suitable for Fiat Punto petrol engines.

Chiave per il tensionamento del cuscinetto tendicinghia, motori Fiat Punto benzina.



Special tools

313 035 000

Flywheel locking tool for Fiat D, TD, JTD engines.

Blocca volano per motori Fiat D, TD, JTD.



Special tools

313 041 000

Special belt-stretcher suitable for Fiat Seicento petrol engines.

Chiave per il tensionamento del cuscinetto tendicinghia, motori Fiat Seicento benzina.

313 151 000

Corteco introducer for the camshaft on Alfa 147, Fiat Stilo 1.9 JTD 16v.

Attrezzo introduttore "Corteco" per albero distribuzione Alfa 147, Fiat Stilo 1.9 JTD 16v.

Special tools**313 152 000**

Locker for crankshaft pulley on motore Fiat 1.7, 1.8, 2.0, 2.0 turbo, 2.4 TD, 2.5, 3.0.

Attrezzo per il bloccaggio della puleggia albero motore Fiat 1.7, 1.8, 2.0, 2.0 turbo, 2.4 TD, 2.5, 3.0.

Special tools**313 154 000**

Locker for the pulleys of the injection pumps, distribution and auxiliary system on Fiat engines.

Attrezzo per il bloccaggio pulegge pompa iniezione, distribuzione e ausiliario, motori Fiat.

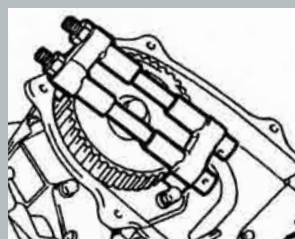
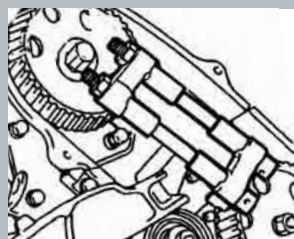
**Special tools****313 171 000**

Special engagement tool, suitable for pulleys.

Attrezzo per ritegno puleggia.

Models: Doblo, Ducato, Punto, Idea, Multipla, Stylo.

Engines: JTD e Multijet

**Special tools**

Special tools**318 001 000**

Special tool suitable for extracting gearbox locknut, mounted on Fiat Ducato.

Chiave per lo smontaggio della ghiera del cambio Fiat Ducato.

Special tools**318 003 000**

Extractor for drive shaft on bearing stop for Fiat Ducato clutch.

Estrattore albero del comando spingi cuscinetto frizione Fiat Ducato.

Special tools**332 004 000**

Special tool for testing and adjusting handbrake on Fiat Ducato 2.3 JTD.

Attrezzo prova tensionamento freno a mano Fiat Ducato 2.3 JTD.

Special tools**383 000 000**

Extractor for Fiat Ducato axle-shaft.

Forcella estrattore semiassie Fiat Ducato.

Special tools**383 001 000**

Tool for removing axle shaft on Fiat Punto models.

Forcella per estrazione del semiassie Fiat Punto.

310 004 000

Special petrol and diesel timing set, suitable for Ford Zetec & Duratech, D&TD engines.

Kit di fasatura per motori Ford benzina e diesel, Zetec e Duratech, D-TD.

Models:

Ford: Fiesta, Fusion, Courier, Escort, Focus, Puma, Mondeo, Transit, Connect & Cougar (91-04)

Mazda: 121 petrol engines

Volvo: S40, V50 petrol engines.

Engines:

1.2, 1.4, 1.6, 1.7 16v. Belt

1.8 & 2.0 16v. Belt & Chain

1.4, 1.6 16v. Focus & Mazda 121

1.8 D, 1.8 TD

Codes: FUJA, FUJB, FXJA, FXJB, FXJB, FYJA, FYJB, F8JA, F8JB, M7JA, M7JB, DHA, DHB, DHC, DHD, DHE, DHF, DHG, FHA, FHE, L1T, L1V, L1E, L1G, L1H, L1K, RDA, RDB, RKC, RQB, RQC, FXDA/C, FXDB/D, FYDA/C, FYDB/D, FYDH, HWDA

Diesel codes: RFN, RTJ, RTK, RVA, RFK, RKD

**Timing tools****310 102 000**

Complete set of timing tools suitable for petrol engines and diesel:

Cassetta completa per la fasatura dei motori benzina e diesel:

Models:

Ford: Fiesta, Fusion, Courier, Escort, Focus, Puma, Mondeo, Sierra, Transit, Connect & Cougar, Courier, Courier Kombi, Galaxy,

VW: Sharan

Seat: Alhambra

Volvo: S40, V50 Petrol, 1.8 D, 1.8 TD, 240D, 740D, 760D, 940D, 960D Turbo

Mazda: 121

Engines:

Gasoline: 1.2, 1.4, 1.6, 1.6 16v., 1.7 16v. Belt, 1.8 & 2.0 16v. Belt & Chain, 1.4, 1.6 16v. Focus & Mazda 121

Diesels: 1.8D, 1.8TD (88-00), 1.8Di(belt)(98-04), 1.8Tdc belt (01-04), 1.6D, 1.9TDi, 2.5D/TCi (Belts)

Codes: FUJA, FUJB, FXJA, FXJB, FXJB, FYJA, FYJB, F8JA, F8JB, M7JA, M7JB, DHA, DHB, DHC, DHD, DHE, DHF, DHG, FHA, FHE, L1T, L1V, L1E, L1G, L1H, L1K, RDA, RDB, RKC, RQB, RQC, FXDA/C, FXDB/D, FYDA/C, FYDB/D, FYDH, HWDA1Z, AHU, AVG, AFN, D24, D24T, D24TIC, RFN, RTJ, RTK, RVA, RFK, RKD, B4164S3.

Timing tools



Timing tools

310 109 000

Complete set of tools suitable for Ford petrol engines 1.2, 1.4, 1.6 16v. (complete with wrench pulley tool mod. 313 031 000)

Models

Ford: Fiesta, Focus, Puma -

Mazda: 121 -

Volvo: S40, V50 petrol engines.

Engines: 1.2, 1.4, 1.6 16v.

Codes: DHA, DHB, DHC, DHD, DHE, DHF, DHG, FHA, FHD, FHF, FXDA/C, FXDB/D, FYDA/C, FYDB/D, FYDH, L1T, L1V, L1W, M7JA, M7JB, F8JA, F8JV, FUJA, FUJB, FXJA/B, FYJA.



Timing tools

310 114 000

Complete set for timing suitable on Ford engines diesel: 2.0, 2.2, 2.4 Duratorq TDCI 16v.

Cassetta adattabile completa per la fasatura dei motori Ford diesel: 2.0, 2.2, 2.4 Duratorq TDCI 16v.

Models: Focus C-Max, S-Max, Mondeo, Transit, New Galaxy

Engines: 2.0, 2.2, 2.4 Duratorq TDCI 16v

Codes: FMBA/B, D5BA, ABFA, D3FA, D6BA, HJBA/B, F3FA, D2FA, D4FA, F4FA, FIFA, DOFA, QJBA, QJBB, FXFA, H9FA.

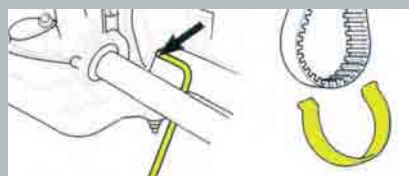

Timing tools

310 063 000

Complete set of tools for camshaft and crankshaft timing on Ford diesel engines.

Set completo di attrezzi per la fasatura e bloccaggio albero motore Ford.

Models:

Ford: Focus, Focus C-Max

Engines: 2.0 TDCI

Codes: G6D4, G6DB, G6DC.

310 115 000

Complete set of timing tools suitable for Peugeot, Citroen, Ford.

Cassetta completa per la fasatura dei motori Peugeot, Citroen, Ford.

Ford

Models: Fiesta, Fusion, Focus, Focus C-Max

Engines: 1.4 -1.6 Duratorq TDCi

Codes: DV4TD(8HW/8HX/8HZ), DV4TED4(8HV/8HY), DV6ATED4 (9HX/9HY/9HZ) F6JA, F6JB, F6JC, G8DA, G8DB

Citroen

Models: Xsara, C2, C3, C4, C5, C8 Evasion

Engines: 1.4 -1.6 Hdi, 1.8-2.0 EW

Codes: DV4TD (8HW/8HX/8HZ) - DV4TED4 (8HV/8HY)-DV6ATED4 (9HX/9HY/9HZ) F6JA -F6JB-F6JC-G8DA-G8DB-EW7J4(6FZ) - EW10J4 (RFN/RFR) EW10J4S (RFK)-EW10-HPi (RLZ)- EW12 (3FZ)

Peugeot

Models: 107, 206, 207, 306, 307, 308, Ranch, Expert, 406, 407, 607, 807

Engines: 1.4 -1.6 Hdi, 1.8-2.0 EW

Codes: DV4TD (8HW/8HX/8HZ) - DV4TED4 (8HV/8HY) -DV6ATED4 (9HX/9HY/9HZ) F6JA-F6JB-F6JC-G8DA-G8DB-EW7J4(6FZ)-EW10J4 (RFN/RFR) EW10J4S (RFK)-EW10-HPi (RLZ)- EW12 (3FZ)

Timing tools**310 123 000**

Complete set of timing tools suitable for Peugeot, Citroen, Ford, Fiat (French engines).

Cassetta completa per la fasatura dei motori Peugeot, Citroen, Ford, Fiat .

Fiat

Models: Ulisse

Engines: 2.0 JTD

Codes: DW10 (RHZ)

Ford

Models: Fiesta Fusion Focus Focus C-Max

Engines: 1.4 -1.6 Duratorq TDCi

Codes: DV4TD(8HW/8HX/8HZ), DV4TED4(8HV/8HY), DV6ATED4 (9HX/9HY/9HZ) F6JA, F6JB, F6JC, G8DA, G8DB

Citroen-Peugeot

Models: Xsara, C2, C3, C4, C5, C8 Evasion, Berlingo, Xsara, Xsara/Picasso, Xantia, Evasion, C5, 206, 306, 307, 406, 407, 607, 107, 207, 308, Ranch, Expert, 807

Engines: 1.4 -1.6 Hdi, 1.8-2.0 EW, 1.9 D, 2.0 Hdi, 2,2 Hdi, 1.8 16v., 2.0 16v.

Codes: DV4TD (8HW/8HX/8HZ) - DV4TED4 (8HV/8HY)-DV6ATED4 (9HX/9HY/9HZ) F6JA -F6JB-F6JC-G8DA-G8DB-EW7J4(6FZ) - EW10J4 (RFN/RFR) EW10J4S (RFK)-EW10-HPi (RLZ)- EW12 (3FZ), DW8 (WJZ), DW10 (RHY-RHZ), DW12 (4HX), EW7J4 (6FZ), EW10J4 (RFR), EW10J4D (RLZ) - HPi

Timing tools

Special tools

**310 089 000**

Set made up of dial gauge d. 60 mm. and support suitable on Ford engines.

Set con supporto comparatore per motori Ford con comparatore d. 40 mm.

Special tools

**313 055 000**

Dialer support for Ford engine.

Supporto per comparatore per motori Ford.

Special tools

**313 031 000**

Special pulley locking tool specific for FORD engines.

Chiave speciale per bloccaggio/rotazione pulegge motori Ford.



Special tools

**313 130 000**

Timing pulleys extractor for Ford engines.

Estrattore per pulegge distribuzione motori Ford.

Special tools

**313 143 000**

Tool for locking flywheel Ford engines.

Attrezzo per il bloccaggio del volano motori Ford.

Special tools

**381 001 000**

Gearbox extractor for Ford models.

Estrattore cambio modelli Ford.

310 013 001

Complete kit to place correctly the camshaft during the timing belt replacement on Opel 2.0 TDI, DTL, DTH, DTX. diesel engines.

Kit per il corretto posizionamento dell'albero camme durante le operazioni di sostituzione cinghia e distribuzione Opel 2.0 TDI, DTL, DTH, DTX.

Models:

Opel: Vauxhall, Astra, Astravan, Zafira, Vectra, Omega, Sintra, Frontera, Signum

Saab: 9-3, 9-5 (98-04)

Engines:

Opel: 2.0 & 2.2 Di

Saab: 2.2 Di with Code: D223L

Codes: X20DTL, X20DTH, X22DTH, Y20DTL, Y20DTH, Y22DTH, Y22DTR

Timing tools**310 019 000**

Timing tools for Opel gasoline engines.

Cassetta fasatura motori - distribuzione Opel benzina 16 v.

Models: Corsa, Agila, Astra, Meriva

Engines: 1.0 12v., 1.0 16v., 1.2 16v., 1.4 16v. (chain)

Codes: X10XE, Z10XE, Z10XEP, X12XE, Z12XE, Z14XEP, Z12XEP, Z14XEL.

Timing tools**310 094 000**

Timing tool for Opel 1.7 TD engine Mod. X17DTL tool for positioning and locking the camshaft.

Attrezzo per la fasatura dei motori Opel 1.7 TD mod. X17DTL.

Models:

Opel: Astra, Cavalier, Vectra-A

Isuzu: Nova, Corsa/Combo, Astra, Cavalier, Vectra, Frontera, Monterey, Midi, Brava

Engines: 1.6D, 1.7D, 1.7DTL

Codes: 16DA, 17D, 17DR, X17DTL, 4EC1, 4EE1, 4JB1, 4XJ1, 4JA1, 4JG2, 4FC1, 4FD1, 4FG1, Z17DT, Y17DT/DTL

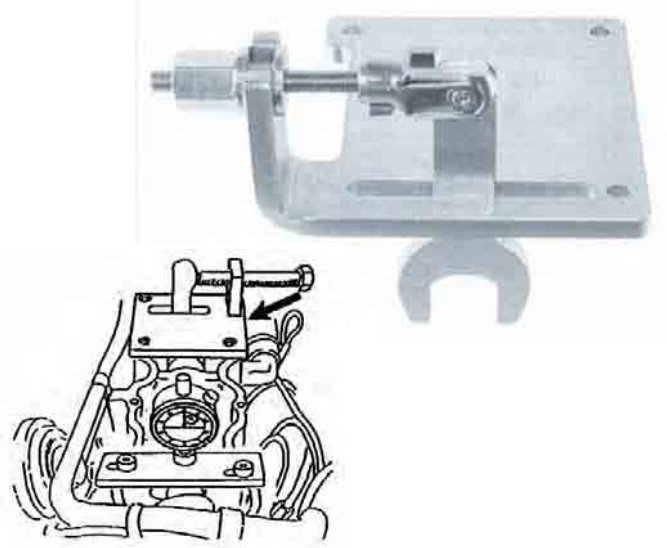
Timing tools

Timing tools

**310 078 000**

Timing tools for Opel gasoline engines and Opel diesel engines. Complete kit to place correctly the camshaft during the timing belt replacement.

Cassetta fasatura motori - distribuzione Opel benzina 16 v. e diesel. Kit per il corretto posizionamento dell'albero camme durante le operazioni di sostituzione cinghia e distribuzione.

Models:

Opel: Corsa, Agila, Meriva, Vauxhall, Astra, Astravan, Zafira, Vectra, Omega, Sintra, Frontera, Signum.

Saab: 9-3, 9-5 (98-04)

Engines: Opel: 1.0 12v., 1.0 16v., 1.2 16V., 1.4 16v. (chain), 2.0 & 2.2 Di. **Saab:** 2.2 Di with Code: D223L

Codes: X10XE, Z10XE, Z10XEP, X12XE, Z12XE, Z14XEP, X20DTL, X20DTH, X22DTH, Y20DTL, Y20DTH, Y22DTH, Y22DTR

Timing tools

**310 107 000**

Set of tools for crankshaft and camshaft timing on new 1.3, 1.9, 2.4 Multijet 140-175 HP. Alfa-Fiat-Lancia, Opel, Suzuki engines.

Cassetta fasatura nuovi 1.9-2.4 jtd Multijet 140cv-175cv, motori Alfa-Fiat-Lancia.

Models:

Opel: Agila, Meriva

Engines: 1.3 CDTI, 1.9 CDTI.

Codes: Z19DTH, Z13DT.

310 008 000

25 pieces set for gasoline timing 1.4 => 3.0 Alfa-Fiat-Lancia.

Cassetta 25 pezzi messa in fase motori benzina Alfa-Fiat-Lancia 1.4 => 3.0.

ART	CAM	CYL N.	ENGINE	N. Pcs
00	A	2	Bravo/Brava- Lancia Y10 1,4 12v.	1
10	A	3	Lancia K 5 cil. 2.0 20v. VIS engine from 1996	2
10	S	2		
20	A	1	Alfa 3.0 V6 24v.	2
20	S	1		
21	A	6		
21	S	4		
40	A	3	Lancia 5 cyl. before '96	2
40	S	2		
50	A	2	Fiat Bravo/Brava/Marea - Lancia 1800 16v 115 HP - Delta/Dedra 1800 16v - 1860 847/C2	2
50	S	3		
60	A	2	Fiat Coupé - Lancia - Alfa 1800 16v 130 HP - Alfa 155	2
60	S	3		
70	A	3	Fiat Bravo/Brava/Marea 2.0 20v	2
70	S	2		
80	A	2	Barchetta/Coupé 1.8 16v variator	2
80	S	3		
90	A	2	Alfa 145/146 1400 16v - 1600 16v (Step A engine only) - Alfa 147 1.6 120HP.	2
90	S	3		
100	A	2	Alfa 156 1600 16v - Alfa 145/146 1400 e 1600 - Alfa 155 1600 16v - with and without variator	2
100	S	3		
105	A	2	Alfa 156 1800-2000 16v - Spider e Gtv TS 2000 - 155 TS 1800	2
105	S	3		
120	A	3	Fiat 2.0 Turbo - Lancia 2.0 Turbo	2
120	S	2		

Timing tools



310 012 000

Timing caps for Lancia, 3.0 liters V6 24v.gasoline engines.

Cassetta cappellotti messa in fase per motori Lancia 3.0 V6 24v.benzina.

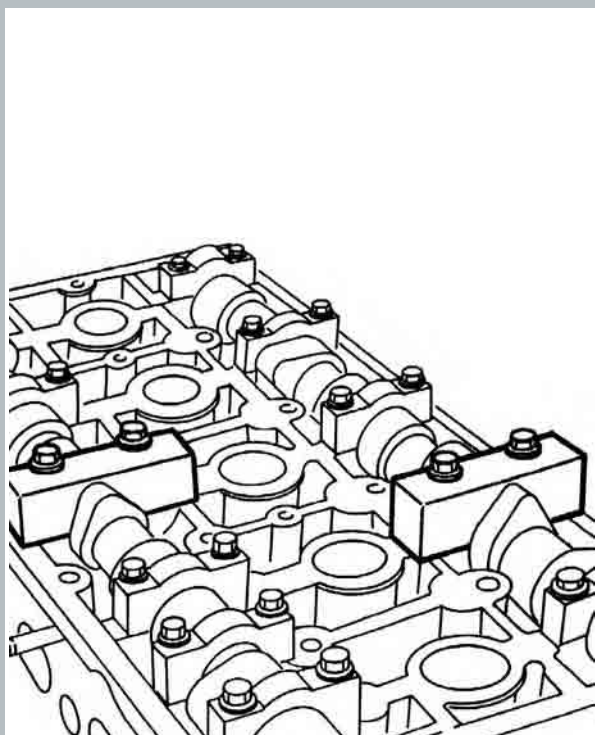

Timing tools



Timing tools



310 074 000

Set of tools for crankshaft and camshaft timing on new 1.9-2.4 Multijet 140-175 cv. Alfa-Fiat-Lancia engines.

Cassetta fasatura nuovi 1.9-2.4 jtd Multijet 140cv-175cv, motori Alfa-Fiat-Lancia.

Models:

Alfa Romeo: 145,146,147,156,159,166,GT

Fiat: Punto,Grande Punto,Brava/Bravo,Marea, Weekend, Stilo, Doblo/Cargo, Multipla

Engines: 1.9 JTD 8v., 1.9 JTD 16v., 2.4 JTD 10v., 2.4 JTD 20v.

Codes: 323.02,371.01, 182B4.000, 182B9.000,186A6.000, 188A2.000,188A7.000, 188B2.000, 192A1.000, 192A3.000, 937A2.000, 939A1.000, 192A5.000, 192B1.000, 37A5.000,939A2.000, 325.01, 342.02,362.02, 185A6.000, 841C.000, 841G.000,939A3.000

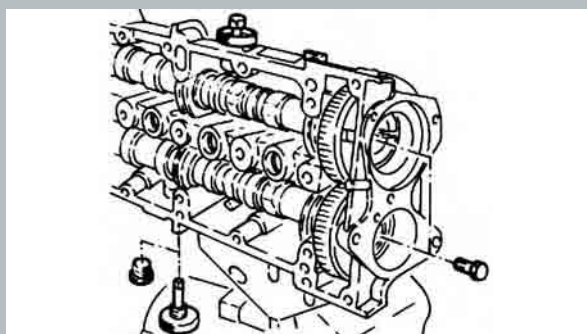

Timing tools



310 075 000

Set of tools for crankshaft and camshaft timing on new 1.3 Multijet 16V. Fiat, Lancia, Opel, Suzuki engines.

Cassetta fasatura nuovi motori 1.3 Multijet 16V. Fiat, Lancia, Opel, Suzuki.

Models: Punto, Panda, Idea, Doblo, Doblo Cargo, Stylo, Ypsilon, Musa, Corsa, Agila, Meriva, Combo Tour, Ignis, Swift, Vagon R+.

Engines: 1.3 Multijet, 1.3 CDTI, 1.3 DDiS.

Codes: 188A8.000, 188A9.000,

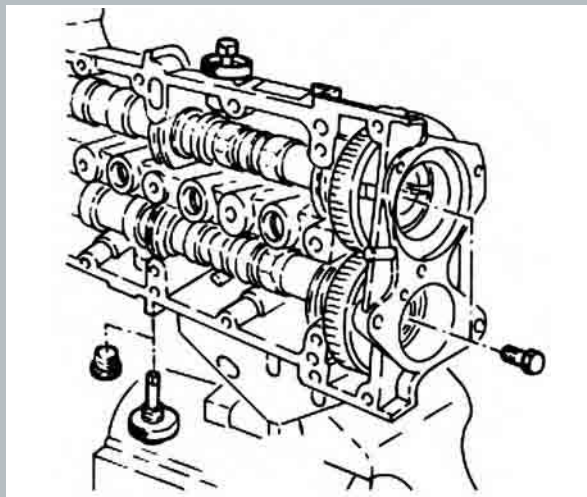

310 107 000

Set of tools for crankshaft and camshaft timing on new 1.3, 1.9, 2.4 Multijet 140-175 HP. Alfa-Fiat-Lancia , Opel, Suzuki engines.

Cassetta fasatura nuovi 1.9-2.4 jtd Multijet 140cv-175cv, motori Alfa-Fiat-Lancia.

Models:

Alfa Romeo: 145,146,147,156,159,166,GT

Fiat: Punto, Grande Punto, Panda, Idea, Brava, Bravo, Marea Weekend, Stilo, Doblo, Doblo Cargo, Multipla

Lancia: Ypsilon, Musa

Opel: Agila, Meriva

Suzuki: Combo Tour, Ignis, Swift, Vagon R+.

Engines: 1.3 Multijet, 1.3 CDTI, 1.3 DDiS., 1.9 CDTI, 1.9 JTD 8v., 1.9 JTD 16v., 2.4 JTD 10v., 2.4 JTD 20v.

Codes: 323.02,371.01, 182B4.000, 182B9.000,186A6.000, 188A2.000,188A7.000, 188A8.000, 188A9.000, 188B2.000, 192A1.000, 192A3.000, 937A2.000, 939A1.000, 192A5.000, 192B1.000, 37A5.000,939A2.000, 325.01, 342.02,362.02, 185A6.000, 841C.000, 841G.000,939A3.000

Timing tools



Timing tools

310 109 000

Complete set of tools suitable for Ford petrol engines 1.2, 1.4, 1.6 16v. (complete with wrench pulley tool mod. 313 031 000)

Cassetta fasatura per motori benzina Ford 1.2, 1.4, 1.6 16v:

Models:

Ford: Fiesta, Focus, Puma

Mazda: 121

Engines: 1.2, 1.4, 1.6

Codes: DHA, DHB, DHC, DHD, DHE, DHF, DHG, FHA, FHD, FHF, FXDA/C, FXDB/D, FYDA/C, FYDB/D, FYDH, L1T, L1V, L1W, M7JA, M7JB

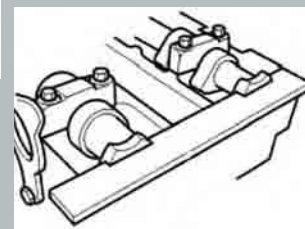
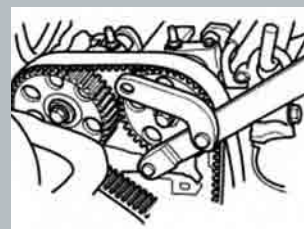

Timing tools

310 102 000

Complete set of timing tools suitable for petrol engines and diesel:

Cassetta completa per la fasatura dei motori benzina e diesel:

Models:

Ford: Fiesta, Fusion, Courier, Escort, Focus, Puma, Mondeo, Sierra, Transit, Connect & Cougar, Courier, Courier Kombi, Galaxy,

VW: Sharan

Seat: Alhambra

Volvo: S40, V50 Petrol, 1.8 D, 1.8 TD, 240D, 740D, 760D, 940D, 960D Turbo

Mazda: 121

Engines:

Gasoline: 1.2, 1.4, 1.6, 1.6 16v., 1.7 16v. Belt, 1.8 & 2.0 16v. Belt & Chain, 1.4, 1.6 16v. Focus & Mazda 121

Diesels: 1.8D, 1.8TD (88-00), 1.8Di(belt)(98-04), 1.8Tdc belt (01-04), 1.6D, 1.9TDi, 2.5D/TCi (Belts)

Codes: FUJA, FUJB, FXJA, FXJB, FXJB, FYJA, FYJB, F8JA, F8JB, M7JA, M7JB, DHA, DHB, DHC, DHD, DHE, DHF, DHG, FHA, FHE, L1T, L1V, L1E, L1G, L1H, L1K, RDA, RDB, RKC, RQB, RQC, FXDA/C, FXDB/D, FYDA/C, FYDB/D, FYDH, HWDA1Z, AHU, AVG, AFN, D24, D24T, D24TIC, RFN, RTJ, RTK, RVA, RFK, RKD, B4164S3.



310 063 000

Complete set of tools for camshaft and crankshaft timing on Citroen - Peugeot DW8 — DW10 — DW12 (HDI) diesel engines.

Set completo di attrezzi per la fasatura e bloccaggio albero motore Citroen – Peugeot DW8 – DW10 – DW12 (Hdi).

Models:

Citroen: Xsara, Xsara Picasso, C2, C3, C4, C5, Xantia, Evasion, Evasion Synergie, Berlingo, Dispatch, Dispatch Jumpy, Relay, Relay Jumper

Peugeot: 206, 306, 307, 406, 406 Coupe, 607, 807, Expert, Partner, Boxer

Fiat: Ulysse, Scudo, Ducato (under JTD Reference)

Volvo: S40 / V50

Ford: Focus, Focus C-Max

Engines: 1.4, 1.6, 2.0, 2.0 D, 2.0 TDCI, 2.2 HDi

Codes: DV4TD(8HW/8HX/8HZ), DV4TED4(8HV/8HY), DV6TED4(9HX/9HY/9HZ), DW10TD(RHY), DW10ATED/L3/L4, (RHS/RHW/RHZ), DW10BTED4/LB(RHR/RHX), DW10UTD(RHN), DW12ATED(4HW/4HX), DW12UTED(4HY), D4204T/2, G6D4, G6DB, G6DC.

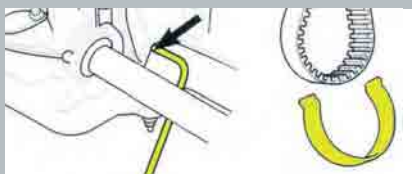

Timing tools



310 064 000

Complete set of tools for camshaft and crankshaft timing on Citroen Peugeot EW 16v gasoline engines.

Set completo di attrezzi per la fasatura e bloccaggio albero motore Citroen – Peugeot "EW".

Models:

Citroen: C5, Xara, Xara Picasso

Peugeot: 206, 306, 406

Engines: 1.8 16v, 2.0 16v

Codes: EW7J4(6FZ), EW10J4(RFR), EW10J4D (RLZ), EW10J4 (RFR), EW7J4 (6FZ), EW10J4 (RFR), EW10J4D (RLZ),

Timing tools



Timing tools



310 099 000

Complete set of timing tools suitable for petrol and diesel engines.

Cassetta completa per la fasatura dei motori benzina.

Models:

Citroen: Xsara, Xsara Picasso, C2, C3, C4, C5, Xantia, Evasion, Evasion Synergie, Berlingo, Dispatch, Dispatch Jumpy, Relay, Relay Jumper

Peugeot: 206, 306, 307, 406, 406 Coupe, 607, 807, Expert, Partner, Boxer

Fiat: Ulysse, Scudo, Ducato (under JTD Reference)

Engines: petrol: 1.4, 1.6, 1.8 16v, 2.0, 2.0 16v
diesel: 2.0 D, 2.0 TDCI, 2.2 HDi

Codes: EW7J4(6FZ), EW10J4(RFR), EW10J4D (RLZ), EW10J4 (RFR), EW7J4 (6FZ), EW10J4 (RFR), EW10J4D (RLZ), DV4TD(8HW/8HX/8HZ), DV4TED4(8HV/8HY), DV6TED4(9HX/9HY/9HZ), DW10TD(RHY), DW10ATED/L3/L4, (RHS/RHW/RHZ), DW10BTED4/LB(RHR/RHX), DW10UTD(RHN), DW12ATED(4HW/4HX), DW12UTED(4HY), D4204T/2, G6D4, G6DB, G6DC.

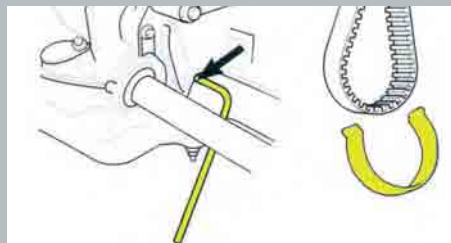

Timing tools



310 115 000

Complete set of timing tools suitable for Peugeot, Citroen, Ford, Volvo.

Cassetta completa per la fasatura dei motori Peugeot, Citroen, Ford, Volvo.

Models:

Ford: Fiesta, Fusion, Focus, Focus C-Max

Citroen : Xsara, C2, C3, C4, C5, C8 Evasion

Peugeot: 107, 206, 207, 306, 307, 308, Ranch, Expert, 406, 407, 607, 807

Volvo: S40 / V50

Engines: 1.4 -1.6 Hdi, 1.6 Duratorq TDCi, 1.6 D, 1.8-2.0 EW.

Codes: DV4TD (8HW/8HX/8HZ), DV4TED4 (8HV/8HY), DV6ATED4 (9HX/9HY/9HZ), F6JA, F6JB, F6JC, G8DA, G8DB, EW7J4(6FZ), EW10J4(RFN/RFR), EW10J4S(RFK), EW10-HPi (RLZ), EW12 (3FZ), D4164T.

310 123 000

Complete set of timing tools suitable for Peugeot, Citroen, Ford, Fiat (French engines).

Cassetta completa per la fasatura dei motori Peugeot, Citroen, Ford, Fiat .

Models:

Fiat: Ulisse

Ford: Fiesta Fusion Focus Focus C-Max

Citroen-Peugeot: Xsara, C2, C3, C4, C5, C8 Evasion, Berlingo, Xsara, Xsara/Picasso, Xantia, Evasion, C5, 206, 306, 307, 406, 407, 607, 806, 107, 207, 308, Ranch, Expert, 807

Engines: 1.4 -1.6 Hdi, 1.4 -1.6 Duratorq TDCi, 1.8-2.0 EW, 1.9 D, 2.0 Hdi, 2.0 JTD, 2,2 Hdi, 1.8 16v., 2.0 16v.

Codes: DV4TD (8HW/8HX/8HZ) - DV4TED4 (8HV/8HY)-DV6ATED4 (9HX/9HY/9HZ) F6JA -F6JB-F6JC-G8DA-G8DB-EW7J4(6FZ) - EW10J4 (RFN/RFR) EW10J4S (RFK)-EW10-HPi (RLZ)- EW12 (3FZ), DW8 (WJZ), DW10 (RHY-RHZ), DW12 (4HX), EW7J4 (6FZ), EW10J4 (RFR), EW10J4D (RLZ) - HPi

Timing tools



Timing tools



310 003 000

Complete timing set for Renault 16V. gasoline engines.

Kit completo per la messa in fase dei motori Renault 16 v. benzina.

Models:

Renault: Clio, Clio Sport, Megane, Megane Scenic, Vel Satis, Avantime, Kangoo, Laguna, Espace.

Nissan: Note, Qashqai.

Engines: Petrol: 1.4, 1.6, 1.8, 2.0 16v.

Codes: K4J/K4M, F4P/F4R

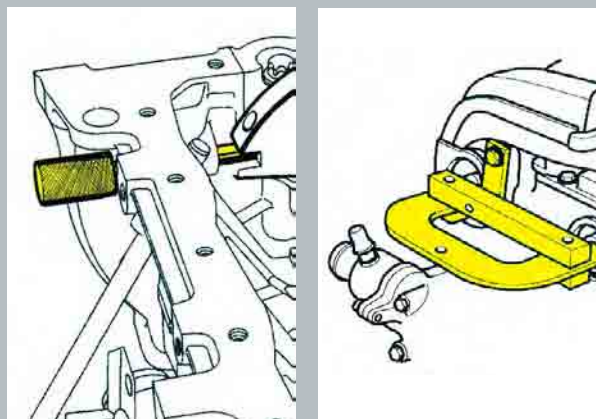

Timing tools



310 073 000

Set of tools for crankshaft timing on Renault 16v gasoline engines + locker for distribution pulleys on 1.4 — 1.6 16v.

Cassetta fasatura motori - distribuzione Renault benzina + piastra bloccaggio pulegge distribuzione 1.4 – 1.6 benzina.

Model: Clio, Clio sport, Megane, Scénic, Laguna, Espace

Nissan: Note, Qashqai

Engines: 1.4 - 1.6 16v, 1.8 16v, 2.0 16v

Codes: K4J 712/713/750, K4M 700/701/720/724/748, F4P 760, F4R 700/701/730/740/741/744/780

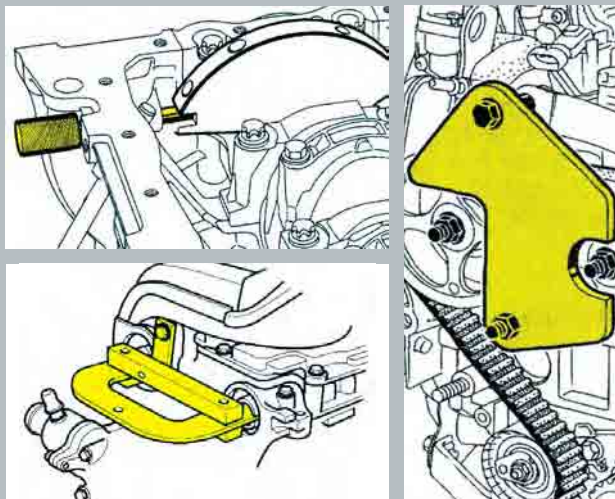

310 083 000

Complete set for camshaft and crankshaft timing on Renault diesel engines:

Cassetta fasatura albero motore, albero camme motori Renault diesel:

Models: Laguna, Espace, Master, Clio, Kangoo

Nissan: Micra, Interstar, Primastar, Qashqai

Engines: 1.5 dCi, , 2.2 dCi, 2.2/2.5 dCi

Codes: G9T 710/720, G9U ,K9K dal 2001, G9U 730, G9T 722/750, G9U 720/724/726/750/754

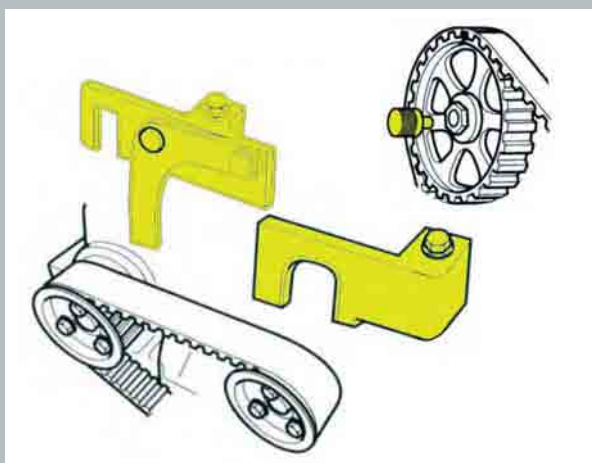
**Timing tools****310 090 000**

Set for crankshaft and camshaft timing on Renault diesel engines.

Cassetta fasatura albero motore, albero camme motori Renault diesel.

Models: Laguna, Espace, Master

Nissan: Interstar, Primastar

Engines: 2.2dCi, 2.5dCi

Codes: G9T 710/720, G9U, G9T 710/720, G9U, G9U 730, G9T 722/750, G9U 720/724/726/750/754.

Timing tools

Timing tools



310 091 000

Complete set for camshaft and crankshaft timing on Renault diesel engines.

Cassetta fasatura albero motore, albero camme motori Renault diesel.

Models:

Renault: Mégane/Scénic, Laguna, Trafic, Twingo, Clio, Kangoo.

Volvo: S40 / V40

Nissan: Qashqai, Kubistar, Interstar

Engines: 1.9 TD, 1,9, 1.9 dCi, 1.2, 1.2 16v.

Codes: F9Q 732, F9Q 718, F9Q 760, F9Q 732, F9Q 750, F9Q 754, D4192T3/4, D7F 700/701/703/710/730 (1995-06) - D4F, 702/704/706/708/712/714/716/730 (2000-06), D7F 726, D4F 712, F9Q, 772/774.

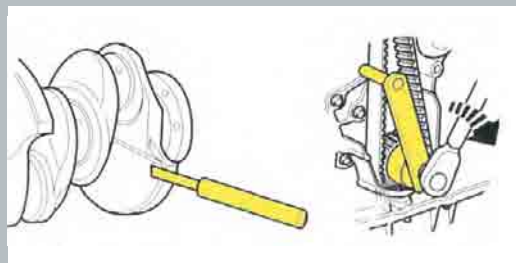

Timing tools



310 092 000

Set for crankshaft and camshaft timing on Renault diesel engines.

Cassetta fasatura albero motore, albero camme motori Renault diesel.

Models:

Renault: Clio, Kangoo.

Nissan: Kubistar, Micra, Note, Qashqai

Engines: 1.5 dCi.

Codes: K9K from 2001, K9K 702/704/710.



310 096 000

Set for camshaft and crank timing on 1.5D and petrol Renault engines.

Cassetta fresatura motori 1.5 diesel e benzina.

Models:

Renault: Clio, Clio Sport, Megane, Megane Scenic, Vel Satis, Avantime, Kangoo, Laguna, Espace.

Nissan: Micra, Note, Qashqai

Engines: Petrol: 1.4, 1.5 dCi, 1.6, 1.8, 2.0 16v.

Codes: K4J/K4M, F4P/F4R, K9K from 2001.

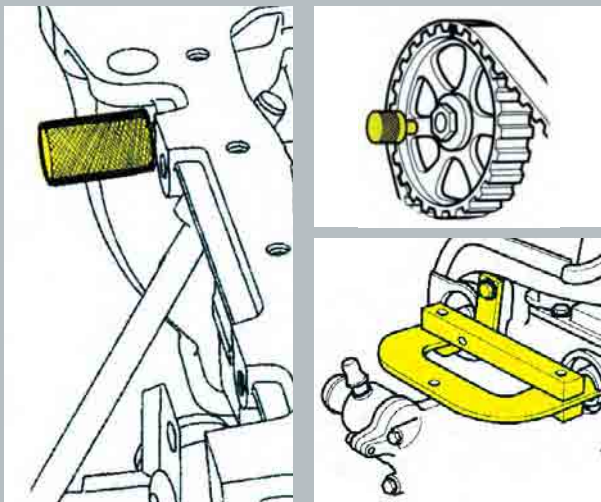
**Timing tools****310 101 000**

Complete set of tools suitable for timing, crankshaft locking, camshaft and pulleys locking on diesel engines.

Cassetta completa per la fasatura, bloccaggio albero motore, albero a camme e pulegge per i motori diesel.

Models:

Renault: Clio, Kangoo, Laguna, Espace, Master, Mégane/Scénic, Trafic.

Nissan: Kubistar, Interstar, Quashqai

Engines: 1.5 dCi, 1.9 TD, 1,9, 1.9 dCi, 2.2dCi, 2.5dCi.

Codes: K9K from 2001, F9Q 732, F9Q 718, F9Q 760, F9Q 732, F9Q 718, F9Q 760, F9Q 750, F9Q 754, G9T 710/720, G9U,

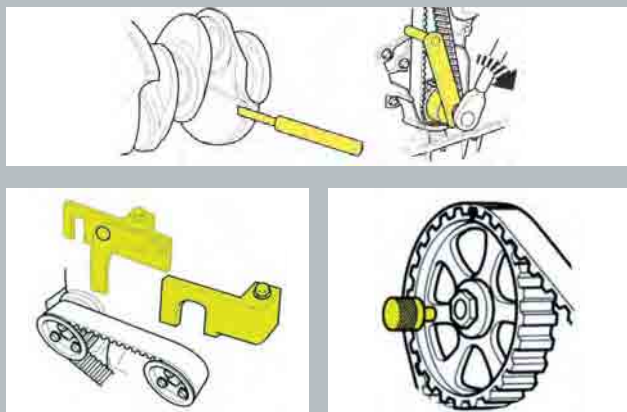
**Timing tools**

Timing tools



310 108 000

Complete set of tools suitable for timing, crankshaft locking, camshaft and pulleys locking on diesel and petrol engines.

Cassetta completa per la fasatura, bloccaggio albero motore, albero a camme e pulegge per i motori diesel e benzina.

Models: Clio, Clio Sport, Megane, Master, Mégane Scenic, Vel Satis, Avantime, Kangoo, Laguna, Espace, Trafic.

Engines: 1.2, 1.4, 1.5 dCi, 1.6, 16v, 1.6D, 1.7, 1.8, 1.8 16v, 1.9 TD, 1.9, 1.9 dCi, 2.0 16v., 2.1TD, 2.2 dCi, 2.2 TD, 2.5 dCi, 2.5 TD, 2.8 D.

Codes: D7F, E5F, E6J, E7F & E7J, K4J/K4M, K7M, F4P/F4R, K4J 712/713/750, K4M 700/701/720/724/748, F1N, F2N, F3N, F2R, F3P, F4P, f3r, 760, F4R 700/701/730/740/741/744/780, G9T 710/720, G9U, K9K dal 2001, F9Q 732, F9Q 718, F9Q 760, F9Q 732, F9Q 718, F9Q 760, F9Q 732, F9Q 718, F9Q 760, F9Q 750, F9Q 754, J5T, J6R, J7R, J7, F7PT, N7Q, N7U, F8M, F8Q, F9Q, J8S, G8TG8, S8U, S9U, S9WT.

Timing tools

310 113 000

Complete set for timing suitable on Renault petrol engines.

Cassetta adattabile completa per la fasatura dei motori benzina Renault.

petrol:

1.2(D7F), 1.4(E5F, E6J, E7F & E7J), 1.6(K7M), 1.7-1.8 (F1N, F2N, F3N, F2R, F3P), 2.0(f3r), 2.0-2.2 (J5T, J6R, J7R, J7T),

Twin Cams: 1.4-1.6, 1.8-2.0 (F7P, F7R), 2.0-2.5 (N7Q, N7U)

Diesel:

1.6D-1.9D/TD (F8M, F8Q, F9Q), 2.1TD (J8S), 2.2D/TD (G8T), 2.5D/TD-2.8D (S8U, S9U, S9W)



313 167 000

Pulleys locker for Renault petrol engines.

Attrezzo blocca pulegge motori Renault benzina

Special tools**313 170 000**

Timing tool for Renault petrol engines from 2001 on.

Staffa fasatura motori Renault benzina 1.8-2.0 dal 2001 in poi.

Models: Megane (99-03), Laguna 2 (01-05).

Engines: 1.8, 2.0 16v. IDE - 5FR (Belt)

Codes: F5R, 700, 701, 740

Special tools**314 021 000**

Special tool for head centering on Renault engines.

Attrezzo per centraggio testate, motori Renault.

Special tools**316 007 000**

Belt extractor of air-conditioning and auxiliary system on Renault engines.

Attrezzo smontaggio cinghia clima-ausiliari motori Renault.

Special tools

Timing tools

**310 107 000**

Complete set of timing tools suitable for 16v. diesel engines.

Cassetta fasatura per motori diesel 16v.

Models:

Alfa 145, 146, 147, 156, 159, 166, GT, Crosswagon Q4

Fiat Punto, Grande Punto, Bravo/Brava, Marea, Weekend, Stylo, Doblò/Cargo, Multipla, Idea, Panda

Lancia Ypsilon, Musa, Lybra, Thesys

Opel Corsa, Agila, Meriva, Combo Tour, Astra, Zafira, Vectra

Suzuki Ignis, Swift, Vagon R+, Grand Vitara, Crossover

Engines:

1.3 Multijet 16V, 1.3 Multijet CDTI, 1.3 DDiS 16V.

1.9-2.4 JTD Multijet, 1.9 CDTI, 1.9 DDiS

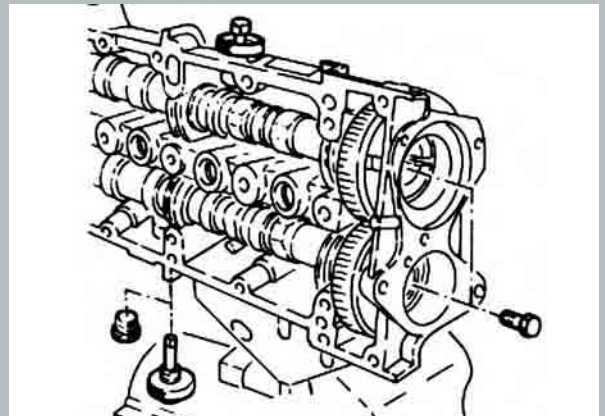

Timing tools

**310 075 000**

Set of tools for crankshaft and camshaft timing on new 1.3 Multijet 16V. Fiat, Lancia, Opel, Suzuki engines.

Cassetta fasatura nuovi motori 1.3 Multijet 16V. Fiat, Lancia, Opel, Suzuki.

Models:

Punto, Panda, Idea, Doblo, Doblo Cargo, Stylo, Ypsilon, Musa, Corsa, Agila, Meriva, Combo Tour, Ignis, Swift, Vagon R+.

Engines: 1.3 Multijet, 1.3 CDTI, 1.3 DDiS.

Codes: 188A8.000, 188A9.000,

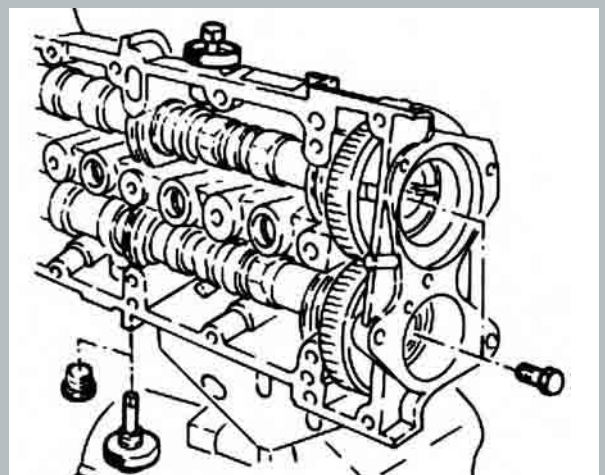

310 063 000

Complete set of tools for camshaft and crankshaft timing on diesel engines.

Set completo di attrezzi per la fasatura e bloccaggio albero motore.

Models S40 / V50.

Engines: 2.0 D.

Codes: D4204T/2

Timing tools**310 091 000**

Complete set for camshaft and crankshaft timing on diesel engines.

Cassetta fasatura albero motore, albero camme motori diesel.

Models: S40 / V40

Engines: 1.9 TD.

Codes: D4192T3/4

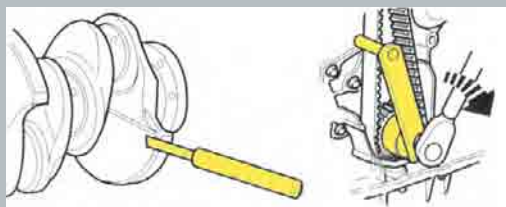
Timing tools



Timing tools

310 102 000

Complete set of timing tools suitable for petrol engines and diesel.

Cassetta completa per la fasatura dei motori benzina e diesel.

Models: S40/V50

Engines: 1.6 16v.

Codes: B4164S3



Timing tools

310 115 000

Complete set of timing tools suitable for Volvo.

Cassetta completa per la fasatura dei motori Volvo.

Models: S40 / V50

Engines: 1.6 D

Codes: D4164T



Timing tools

310 108 000

Complete set of timing tools suitable for gasoline engines.

Cassetta completa per la fasatura, adattabile per i motori a benzina.

Engines: 2.0 twin cams.

Codes: B5254, B5234, B5204

310 000 000

Timing set for Volkswagen-Audi-Seat-Skoda 1.7, 1.9, 2.5 TDI diesel engines & 1.6, 2.0 petrol engines

Cassetta completa per la fasatura dei motori Volkswagen-Audi, Seat, Skoda 1.7, 1.9, 2.5 TDI diesel & 1.6, 2.0 benzina

Models:

Audi: 80, A3, S3, A4, A6, TT, Cabriolet

Seat: Ibiza, Cordoba, Arosa, Leon, Inca, Toledo, Alhambra

Skoda: Fabia, Felicia, Octavia, Superb

Volkswagen: Lupo, Polo/Classic, Caddy, Golf, Bora, Beetle, Passat, Touran, Sharan, Transporter

Engines: 1.7, 1.9, 2.5 D/SDi/TDi diesel & 1.6-2.0 petrol

Codes:

1Z, 1Y, 1X, 1F, 2E, AAZ, AAE, AAC, ABF, ABL, ABM, ABK, ABT, ABS, ACE, AEK, AEY, AEF, AEH, AEB, AEG, ADY, ADA, ADR, ADP, ADZ, ADL, AFF, AFN, AFT, AGG, AGR, AGP, AGD, AGN, AGU, AHL, AHF, AHU, AHH, AHG, AHB, AJQ, AJL, AJP, AJH, AKU, AKW, AKL, AKS, ALH, ALE, ALZ, AMK, ANA, ANB, APK, APX, APU, APF, APG, APP, APY, APT, AQM, AQA, AQX, AQY, ARX, ARY, ARZ, ARM, ARG, ASV, ASY, ASX, ATM, ATU, AUM, AUQ, AUR, AVG, AVU, AVC, AXW, AXA, AWU, AWG, AWT, AWC, AWF, AYQ, AYP, AYD, AZH, AZJ, AZM, BAM, BEH, BFQ, BFS, BGU

Timing tools



310 017 000

Set of tools for camshaft timing on new Volkswagen, Audi 1.9 TDI, 1.9 SDI 110 HP. diesel engine.

Cassetta fasatura motori - distribuzione Volkswagen, Audi motori 1.9 TDI, 1.9 SDI 110 cv. diesel

Models: Polo, Polo Classic, Golf, Bora, Beetle, Caddy

Engines: 1.9 TDI, 1.9 SDI 110 cv. diesel

Codes: AGP, AGR, AHF, Alh, AQM, ASV

Timing tools



Timing tools



310 039 000

Timing set for Volkswagen-Audi-Seat 1.4 & 1.6 16v. gasoline engines.

Kit per la fasatura dei motori Volkswagen-Audi-Seat 1.4 & 1.6 benzina 16v.

Models:

Seat: Arosa, Ibiza, Cordoba, Toledo, Leon, Inca (99-04)

Skoda: Fabia, Octavia (99-04)

VW: Lupo, Polo/Classic, Beetle, Golf, Bora, Caddy

Engines: 1.4 & 1.6 16v. Twin Cams

Codes: ARC, ATN, AUS, AVY, AZD, AFH, BCA, AFK, AHW, AJV, AKQ, APE, AQQ, AUA, AUB, AXP, AFH, AFK, AHW, APE, AQQ, AUA, AUB, AUS, AXP, AZD, BBY, BBZ, BCB

Timing tools



310 065 000

Complete set for crankshaft timing on new VW - Audi 1.2 - 1.4 - 1.9 TDI engines.

Cassetta fasatura motori - distribuzione VW - Audi motori 1.2 - 1.4 TDI - 1.9 TDI

Models:

Volkswagen: Lupo, Polo, Golf, Bora, Passat, Beetle, Sharan

Audi: A2, A3, A4, A6

Seat: Alhambra

Engines: 1.2 TDI, 1.4 TDI, 1.9 TDI

Codes: AJM, AMF, ANU, ANY, ASZ, ATD, ATJ, AUY, AVB, AVF, AWX, AXR, AYZ

310 077 000

Flywheel locking tools on Fiat - VW - Audi-Seat - Skoda engines.

kit di attrezzi per il bloccaggio del volano Fiat - VW-Audi - Seat -Skoda.

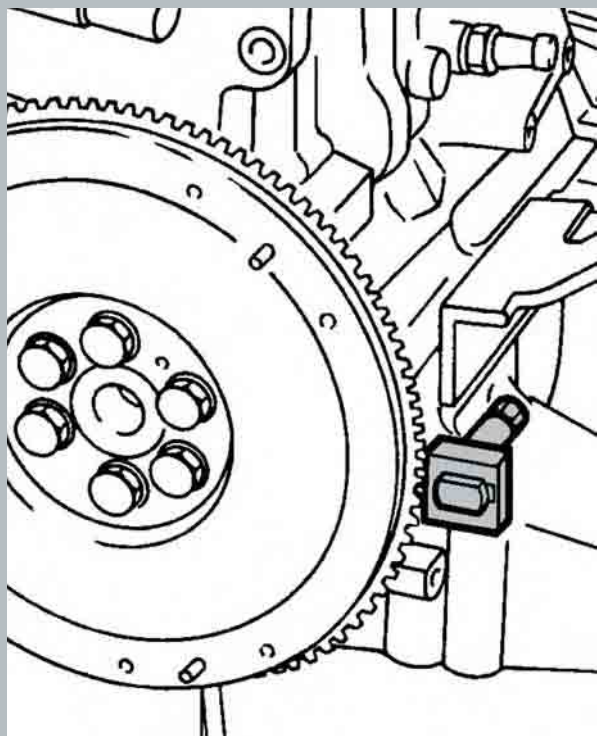

Timing tools



310 098 000

Complete timing set for 1.2 L, 3 cylinders 9v.and 12v. petrol VW engines.

Cassetta fasatura dei motori VW 1.2 cc., 3 cilindri 9v. e 12v.

Models:

Volkswagen: Fox, Lupo, Polo,

Skoda: Fabia

Seat: Ibiza, Cordoba

Engines: 1.2 cc 9v-12v 3 cylinders engine

Codes: AWY, AZQ (55 - 64 HP)

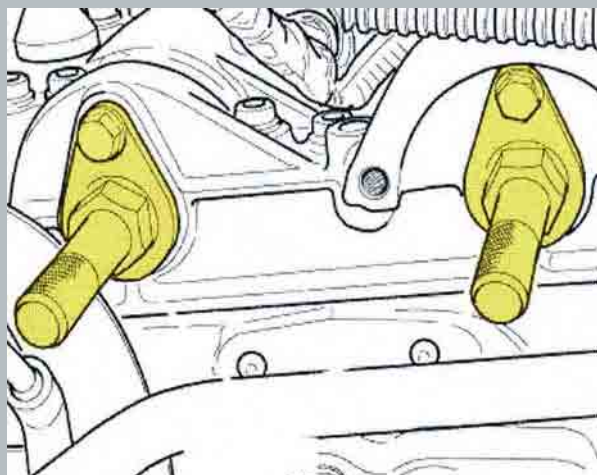

Timing tools



Timing tools



310 102 000

Complete set of tools suitable for diesel engines: 1.9 TDI 75-90-110 Hp, 1.9 SDI 75-90-110 Hp, 1.9 TDI 105-130-150 Hp, 2.0 TDI DPF 140-170 Hp, 1.9 TDI 75-90-110 cv.

Cassetta completa per la fasatura dei motori diesel: 1.9 TDI 75-90-110 Hp, 1.9 SDI 75-90-110 Hp, 1.9 TDI 105-130-150 Hp, 2.0 TDI DPF 140170 Hp, 1.9 TDI 75-90-110 cv.

Models:

Ford: Galaxy (95->00)

Volkswagen: Lupo, Polo, Golf, Bora, Passat, Beetle, Sharan

Audi: A2, A3, A4, A6

Seat: Alhambra (->99)

Volvo: S40, V50 Petrol, 1.8 D, 1.8 TD, 240D, 740D, 760D, 940D, 960D Turbo

Engines:

1.9 TDI 75-90-110 HP, 1.9 SDI 75-90-110 HP, 1.9 TDI 105-130-150 HP, 2.0 TDI DPF 140-170 HP, 1.9 TDI 75-90-110 HP

Codes: AJM, AMF, ANU, ANY, ASZ, ATD, ATJ, AUJ, AVB, AVF, AWX, AXR, AYZ, 1Z, AHU, AVG, AFN, D24, D24T, D24TIC

Timing tools



310 103 000

Complete set of timing tools suitable for VW-Audi-Seat-Skoda, petrol and diesel engines.

Cassetta completa per la fasatura dei motori benzina e diesel.

Models:

Audi: A2,A3,A4,A6,Cabriolet.

Seat: Arosa, Ibiza, Cordoba, Leon, Toledo, Alhambra, Altea, Inca (99-04).

Skoda: Fabia, Octavia, Superb.

Volkswagen: Lupo, Polo, Fox, Golf, Borra, Jetta, Golf Plus, Passat, Beetle, Touran, Sharan, Caddy, Transporter, Ford Galaxy.

Engines: 1.4 & 1.6 16v. Twin Cams

1.2TDi PD, 1.4TDi PD, 1.9 TDI 75-90-110 Hp., 1.9 SDI 75-90-110 Hp., 1.9 TDI 105-130-150 Hp., 2.5 TDI V6.

Codes:

ARC, ATN, AUS, AVY, AZD, AFH, BCA, AFK, AHW, AJV, AKQ, APE, AQQ, AUA, AUB, AXP, AFH, AFK, AHW, APE, AQQ, AUA, AUB, AUS, AXP, AZD, BBY, BBZ, BCB, ANY, AYZ, AMF, ATL, BAY, BHC, BMS, BNM, BNV, BWB, AJM, AMG, ANU, ARL, ASZ, ATD, ATJ, AUJ, AVB, AVF, AVQ, AWX, AXB, AXC, AXR, BEW, BJB, BKC, BKE, BLS, BLT, BMT, BPX, BRB, BRM, BRR, BRS, BRU, BSU, BSW, BTB, BUK, BVK, BXE, BXF, AZV, BDJ, BDK, BGW, BHW, BKD, BKP, BLB, BMA, BMM, BMN, BMP, BMR, BNA, BPW, BRC, BRE, BRF, BRT, BUZ, BE, BVF, BVG, BVH, BWV.

310 116 000

Complete set of tools suitable for VW-Audi-Seat-Skoda 1.2 TDi, 1.4 TDi, 1.9 TDi, 2.0 TDi PD diesel engines. **COMPLETE WITH SPECIAL CRANKSHAFT OVAL PULLEY LOCKER.**

Cassetta adattabile per la fasatura dei motori VW-Audi-Seat-Skoda, diesel: 1.2Tdi, 1.4Tdi, 1.9Tdi, 2.0Tdi PD diesel. **COMPLETO DI BLOCCA PULEGGE ALBERO MOTORE PER PULEGGE OVALI.**

Models:

Audi: A2, A3, A4, A4 Cabriolet, A6

Seat: Arosa, Ibiza, Cordoba, Leon, Toledo, Alhambra, Altea

Skoda: Fabia, Octavia, Superb

Volkswagen: Lupo, Polo, Fox, Golf, Borra, Jetta, Golf Plus, Passat, Beetle, Touran, Sharan, Caddy, Transporter

Ford: Galaxy

Engines: 1.2 TDi, 1.4 TDi, 1.9 TDi, 2.0 TDi PD

Codes:

ANY, AYZ, AMF, ATL, BAY, BHC, BMS, BNM, BNV, BWB, AJM, AMG, ANU, ARL, ASZ, ATD, ATJ, AUJ, AVB, AVF, AVQ, AWX, AXB, AXC, AXR, BEW, BJB, BKC, BKE, BLS, BLT, BMT, BPX, BRB, BRM, BRR, BRS, BRU, BSU, BSW, BTB, BUK, BVK, BXE, BXF, AZV, BDJ, BDK, BGW, BHW, BKD, BKP, BLB, BMA, BMM, BMN, BMP, BMR, BNA, BPW, BRC, BRE, BRF, BRT, BUZ, BE, BVF, BVG, BVH, BWV.

Timing tools**310 117 000**

Set of tools suitable for VW-Audi-Seat-Skoda engines 2.0 TDi PD diesel engines.

Cassetta adattabile per la fasatura dei motori VW-Audi-Seat-Skoda 2.0 TDi PD diesel.

Models:

Audi: A3, A4, A4 Cabriolet, A6

Seat: Leon, Toledo, Alhambra, Altea

Skoda: Octavia, Superb

Volkswagen: Golf, Borra, Jetta, Golf Plus, Passat, Eos, New Beetle, Touran, Sharan, Caddy, Transporter

Ford: Galaxy

Engines: 2.0 TDi PD

Codes: AZV, BKD

Timing tools

Timing tools



310 132 000

Complete set of tools suitable for VW-AUDI-SEAT-SKODA engines, diesel: 1.2 TDi, 1.4 TDi, 1.9 TDi.

Cassetta adattabile per la fasatura dei motori VW-AUDI-SEAT-SKODA, diesel: 1.2 TDi, 1.4 TDi, 1.9 TDi.

Models:

Audi: A2, A3, A4, A4 Cabriolet, A6

Seat: Arosa, Ibiza, Cordoba, Leon, Toledo, Alhambra, Altea

Skoda: Fabia, Octavia, Superb

Volkswagen: Lupo, Polo, Fox, Golf, Borra, Jetta, Golf Plus, Passat, Beetle, Touran, Sharan, Caddy, Transporter

Ford: Galaxy

Engines:

1.2 TDi, 1.4 TDi, 1.9 TDi.

Codes:

ANY, AYZ, AMF, ATL, BAY, BHC, BMS, BNM, BNV, BWB, AJM, AMG, ANU, ARL, ASZ, ATD, ATJ, AUJ, AVB, AVF, AVQ, AWX, AXB, AXC, AXR, BEW, BJB, BKC, BKE, BLS, BLT, BMT, BPX, BRB, BRM, BRR, BRS, BRU, BSU, BSW, BTB, BUK, BVK, BXE, BXF, AZV, BDJ, BDK, BGW, BHW, BKD, BKP, BLB, BMA, BMM, BMN, BMP, BMR, BNA, BPW, BRC, BRE, BRF, BRT, BUZ, BE, BVF, BVG, BVH, BWV.

Timing tools



310 124 000

Complete set of timing tools suitable for VW-Audi-Seat-Skoda, petrol and diesel engines. **COMPLETE WITH SPECIAL CRANKSHAFT OVAL PULLEY LOCKER.**

Cassetta completa per la fasatura dei motori benzina e diesel.

Models:

Audi: A2,A3,A4,A6,Cabriolet.

Seat: Arosa, Ibiza, Cordoba, Leon, Toledo, Alhambra, Altea, Inca (99-04).

Skoda: Fabia, Octavia, Superb.

Volkswagen: Lupo, Polo, Fox, Golf, Borra, Jetta, Golf Plus, Passat, Beetle, Touran, Sharan, Caddy, Transporter, Ford Galaxy.

Engines: 1.4 & 1.6 16v. Twin Cams

1.2TDi PD, 1.4TDi PD, 1.9 TDI 75-90-110 Hp., 1.9 SDI 75-90-110 Hp., 1.9 TDI 105-130-150 Hp., 2.0 Tdi PD, 2.0 TDI DPF 140-170 Hp., 2.5 TDI V6.

Codes: ARC, ATN, AUS, AVY, AZD, AFH, BCA, AFK, AHW, AJV, AKQ, APE, AQQ, AUA, AUB, AXP, AFH, AFK, AHW, APE, AQQ, AUA, AUB, AUS, AXP, AZD, BBY, BBZ, BCB, ANY,AYZ,AMF,ATL,BAY,BHC,BMS,BNM,BNV,BWB, AJM,AMG,ANU,ARL,ASZ,ATD,ATJ,AUJ,AVB,AVF, AVQ,AWX,AXB,AXC,AXR,BEW,BJB,BKC,BKE,BLS, BLT,BMT,BPX,BRB,BRM,BRR,BRS,BRU,BSU,BSW, BTB, BUK, BVK, BXE, BXF, AZV, BDJ, BDK, BGW, BHW, BKD, BKP, BLB, BMA, BMM, BMN, BMP, BMR, BNA, BPW, BRC, BRE, BRF, BRT, BUZ, BE, BVF, BVG, BVH, BWV, AZV, BKD.

310 126 000

Complete set of timing tools suitable for VW, Audi, Skoda, petrol engines. Complete with water pump pulley extractor and crankshaft pulley extractor.

Cassetta completa per la fasatura dei motori benzina VW, Audi, Skoda. Completo di estrattore per la puleggia della pompa dell'acqua, e dell'estrattore per la puleggia albero motore.

Models: Volkswagen: Polo, Golf, Golf Plus, Touran, Passat. **Audi:** A3. **Skoda:** Octavia.

Engines: 1.4 & 1.6 FSi (Chain Drive)

Codes: AXU, BAG, BKG, BLF, BLN, BLP

310 126 011

Complete set of timing tools suitable for VW, Audi, Skoda, petrol engines. Complete with water pump pulley extractor and crankshaft pulley extractor. **Without dial gauge.**

Cassetta completa per la fasatura dei motori benzina VW, Audi, Skoda. Completo di estrattore per la puleggia della pompa dell'acqua, e dell'estrattore per la puleggia albero motore. **Senza comparatore.**

Models: Volkswagen: Polo, Golf, Golf Plus, Touran, Passat. **Audi:** A3. **Skoda:** Octavia

Engines: 1.4 & 1.6 FSi (Chain Drive)

Codes: AXU, BAG, BKG, BLF, BLN, BLP

Timing tools**310 126 010**

Complete set of timing tools suitable for VW, Audi, Skoda, petrol engines.

Cassetta completa per la fasatura dei motori benzina VW, Audi, Skoda.

Models:

Volkswagen: Polo, Golf, Golf Plus, Touran, Passat

Audi: A3

Skoda: Octavia

Engines: 1.4 & 1.6 FSi (Chain Drive)

Codes: AXU, BAG, BKG, BLF, BLN, BLP

Timing tools



Special tool

313 030 000

Belt tensioner for Volkswagen, Audi, Seat, Skoda engines.

Chiave tendicinghia per motori Volkswagen, Audi, Seat, Skoda.



Special tool

313 032 000

Water pump locking tool for Volkswagen Polo, Golf, Passat, Audi 80/A4.

Chiave per il bloccaggio della pompa dell'acqua Volkswagen Polo, Golf, Passat, Audi 80/A4.



Special tool

313 033 000

Water pump locking wrench for Volkswagen, Audi engines (in case of air-conditioning system).

Chiave per il bloccaggio interno della pompa dell'acqua Volkswagen, Audi con climatizzatore.



Special tool

313 038 000

Long Belt tensioner for Volkswagen, Audi, Seat, Skoda, gasoline and diesel engines.

Chiave lunga tendicinghia per motori Volkswagen, Audi, Seat, Skoda, benzina e diesel.



Special tool

313 039 000

Short Belt tensioner for Volkswagen, Audi, Seat, Skoda, gasoline and diesel engines.

Chiave corta tendicinghia per motori Volkswagen, Audi, Seat, Skoda, benzina e diesel.



Special tool

313 126 000

Belt tensioner for Volkswagen, Audi, Seat, Skoda, gasoline and diesel engines.

Chiave tendicinghia per motori Volkswagen, Audi, Seat, Skoda, benzina e diesel.

315 020 000



Air operated valve spring compressor:

Case Dimensions: 485 x 375 x 135 mm.
Machine weight: 5 Kg.
Alimentation: Air pressure min 6 bar., max 10 bar
Power: 6 bar=75 Kg, 10 bar=100 Kg.

Universal pneumatic tool for assembling and disassembling engine valves, suitable for all types of valves on petrol and diesel engines. Practical and easy to use, it permits time saving up to 60-70%, especially during valve assembly. APPOSITELY MADE FOR ENGINES WITH 4/5 VALVES FOR CYLINDER.

CE approved machine in compliance with 98/37/CE (Machine Directive)

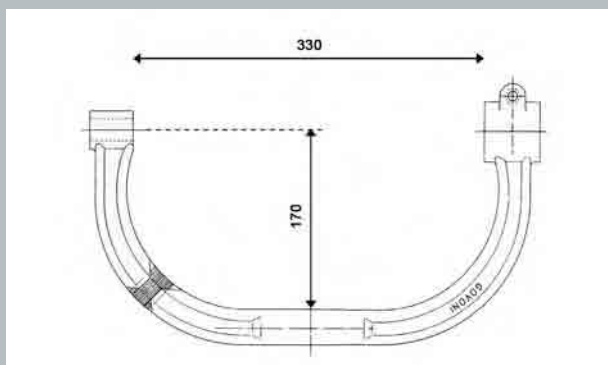

Engine - valves



Included



315 020 002

Pressure foot d. 25,5 with 5 adaptors:
24,5 - 25 - 27 - 29 - 32 mm.



315 020 002

315 020 003

Pressure foot d. 34 with 3 adaptors:
34 - 41 - 50 mm.



315 020 003

315 020 006

Pressure foot d. 19,8 mm.

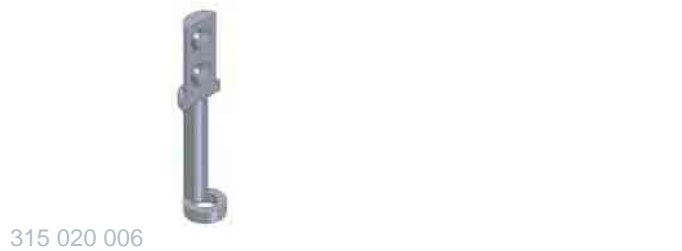

315 020 006

Engine - valves

315 021 000



Air operated Heavy Duty valve spring compressor:

Case Dimensions: 485 x 375 x 135 mm.
 Machine weight: 6 Kg.
 Alimentation: Air pressure min 6 bar., max 10 bar
 Power: 6 bar=118 Kg, 10 bar=157 Kg.

Universal pneumatic tool for assembling and disassembling engine valves, suitable for all types of valves on petrol and diesel engines. Practical and easy to use, it permits time savings of up to 60-70%, especially during valve assembly. APPOSITELY MADE FOR ENGINES WITH 4/5 VALVES FOR CYLINDER.

CE approved machine in compliance with 98/37/CE (Machine Directive)

Designed for commercial vehicles, trucks, caterpillar, special engines

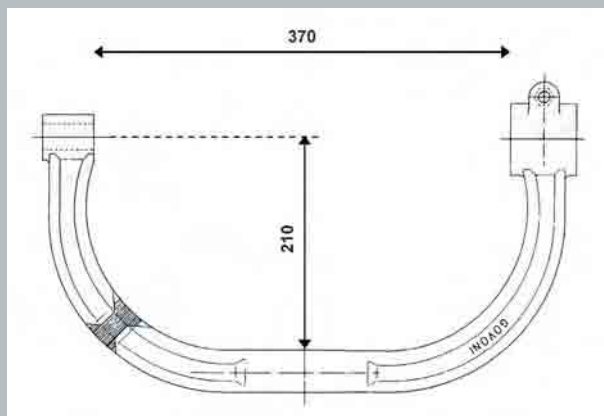

Included

315 020 002

Pressure foot d. 25,5 with 5 adaptors: 24,5 - 25 - 27 - 29 - 32 mm.

315 020 003

Pressure foot d. 34 with 3 adaptors: 34 - 41 - 50 mm.

315 020 006

Pressure foot d. 19,8 mm.



315 020 002



315 020 003

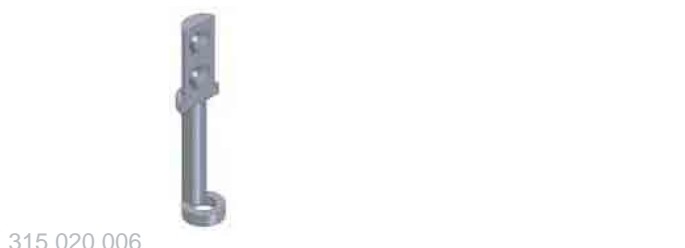

315 020 006

315 019 000

Manual bench useful to assembly and disassembly engine valves complete with three pressure feet.

Technical data:

Dimensions: A=785 mm. B=500 mm. C=625 mm.
 Stroke: D = 265 mm.
 Cylinder Head: 750 mm. max length: 185 mm. min
 Cylinder Head: inclination=0-30°
 Total Weight: 25,5 kg.

The two head supports are implemented with non-scratch plastic material and are adjustable from 0 to 30°.

There are two handles for locking when the right inclination is set.

It is also possible to regulate the horizontal position of the head moving the pins to the apposite holes up and down. There is a long regulation also for the push rod in case of deep valve chambers. The frame can be rotated 30° on both sides.

Moreover can be regulated also forward and backwards. In case of valves locked hard into the seat, hit on the slide hammer on the top with a plastic mallet. The bench is also provided with a Travel limit device that guarantees the same stroke for each valve.

Meanwhile the valve spring is compressed, the operator can block the position using the apposite pin. Consequently he can work on the valves having both hands free.

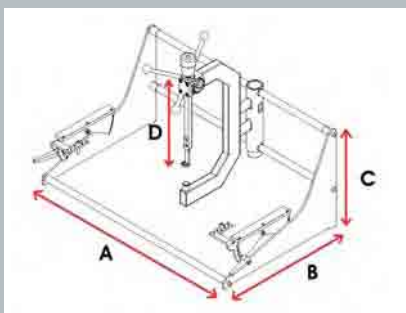

Engine - valves

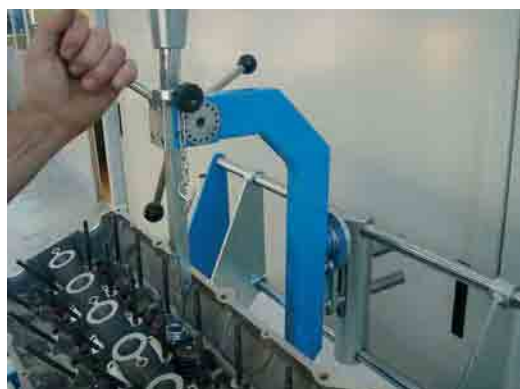

Included



315 020 002

Pressure foot d. 25,5 with 5 adaptors: 24,5 - 25 - 27 - 29 - 32 mm.

315 020 003

Pressure foot d. 34 with 3 adaptors: 34 - 41 - 50 mm.

315 020 006

Pressure foot d. 19,8 mm.



315 020 002



315 020 003



315 020 006

Engine - valves



315 024 000



Extra Heavy Duty pneumatic Valve Spring compressor.

Machine Dimensions: 630 x 300 x 95 mm.
 Case Dimensions: 485 x 375 x 185 mm.
 Machine weight: 7,2 Kg.
 Packaging weight: 9 Kg.
 Alimentation: Air pressure min 6 bar., max 10 bar
 Power: 10 bar=500 Kgf.

Full Pressure feet equipped

Jaws handle springs from 19 mm. to 50 mm. (3/4" to 2") diameter. Quick and precise adjustment in millimeters increments thanks to its locking handle.

Cylinder: Stroke

Cylinder stroke is 90 mm. (3" 1/2) that allows to compress any kind of springs and at same time guarantees safety;

Cylinder: High Power

It needs only 6 bar (90 psi) of compressed air to operate. With a working pressure of 10 bar (145 psi) the Spring Compressor force is 500 kgf. (1.102 lbf);

Aluminium Technology

The cylinder is made in light alloy and nylon resin with fibreglass avoiding consequently the corrosion and the oxidation of the parts of the machine;

Strong C-Frame system

Heavy-duty frame is CNC-machined and made of quality steel;

Safety Valve

The drive valve can function only when the Spring Compressor is connected to the compressed air system. Consequently the machine can be disconnected while the spring is compressed without dangers assuring the maximum safety.

Easy and quick to place and handle. It needs only to be connected to the air system.

CE approved machine in compliance with 98/37/CE (Machine Directive)

Included



315 005 000

Pressure foot d. 25,5 with 5 adaptors: 24,5 - 25 - 27 - 29 - 32 mm.



315 005 000

315 009 000

Pressure foot d. 34 with 3 adaptors: 34 - 41 - 50 mm.



315 009 000

315 020 007

Valve keeper with double magnet on both sides.
Lenght= 165 mm.

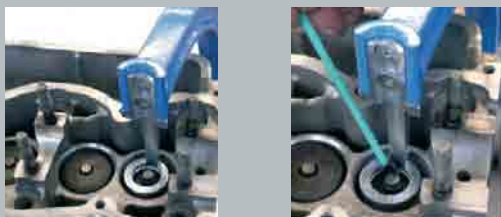
**Engine - valves****314 011 000**

Special head support useful to resurface cylinder head
on Fiat 1.6 16v gasoline engines.
Supporto per rettifica testate dei motori Fiat 1.6 litri 16v.

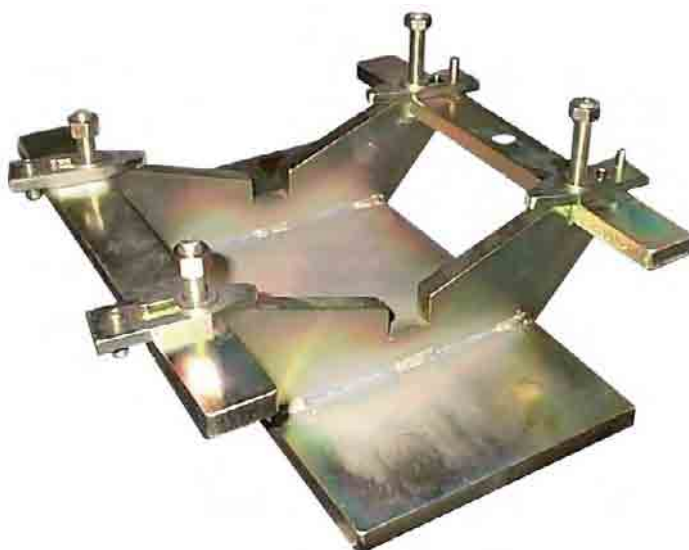
**Engine - valves****315 007 000**

Cylinder head support facilitates a wide range of operations on any type of cylinder head (valve assembling/disassembling, valve-seat grinding, conduits cleaning, tappets adjustment, etc.). The support can be adjusted to suit cylinder heads from cm.6 to 90, thanks to the sliding arms with lock knob for length adjustment, and to the support plates in scratch-proof plastic material, which can be roated in 360°. The mod. 315 007 000 may be held in a vice or, using the holes provided, fixed to an engine stand.

Il supporto testate motori permette di effettuare le lavorazioni (smontaggio e rimontaggio valvole, rettifica sedi, pulizia condotti, registrazione punterie, ecc.) su qualsiasi tipo di testata motore da cm. 6 a 90 grazie ai bracci scorrevoli con pomello di fermo per regolazione distanza, ed ai piani di appoggio a rotazione 360°.

Engine - valves

Spirals

321 000 000



Universal pneumatic machine for assembling and disassembling shock absorbers.

Machine Dimensions: 650 x 400 x 1400 mm.

Packaging Dimensions: 520 x 300 x 1400 mm.

Machine weight: 65 Kg.

Alimentation: Air pressure min 6 bar., max 10 bar

Power: 6 bar=735 Kg, 10 bar=1.226 Kg.

Cylinder stroke: 420 mm.

ALS-Auto Leveling System

The two auto leveling upper arms allow to work easily both on conical and misaligned springs.

Cylinder: Stroke & Power

It is possible to use this auto leveling machine also in case of long shock absorbers as the ones installed on commercial vehicles, off roads and wagons, thanks to its 420 mm stroke. With a working pressure of 10 bar the machine exerts a compression force at 1226 kg without losing power.

Aluminium Technology

The cylinder is made in light alloy and nylon resin with fibreglass avoiding consequently the corrosion and the oxidation of the parts of the machine.

Brackets System

The frontal and lateral clamps' holders grant quick mounting and dismounting replacement both of the clamps and of the vice.

Safety guard

The drive valve can function only when the machine is connected to the compressed air system. Consequently the machine can be disconnected while the spring is compressed without dangers assuring the maximum safety. The machine was designed in compliance with the 98/37/CE Machine Directives. The protection permits to work freely and in safety.

Tools Rack

The machine is equipped with a practical and steady tools rack.

CE approved machine in compliance with 98/37/CE (Machine Directive)

Included

321 002 000

Bracket model "A" from Ø 78 mm. to Ø 130 mm.

321 003 000

Bracket model "B" from Ø 125 mm. to Ø 205 mm.



Springs



321 002 000



321 003 000

Included

321 001 000

Blocking vice for shock absorbers.



Springs



321 001 000

Included

321 038 009

Safety guard kit.



Springs

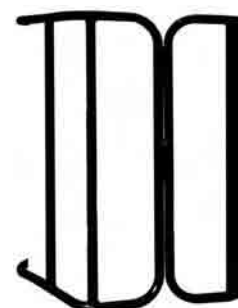

321 038 009

On request

321 030 000

Upper jaws for Japanese models (Toyota, Honda, etc.).



Springs

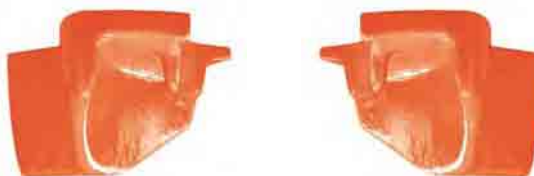

On request

321 028 000

Adjustable support for upholding the strut.



Springs



On request

321 029 000

Bracket model "C" from Ø 105 mm. to Ø 182 mm.
Special for: Renault Megane, Citroen C3 & C2.



Springs



Springs



MERCEDES
320 014 000

Special set of brackets for Mercedes A, B, C, E Class

321 029 000
Bracket model "C"
from Ø 105 mm. to Ø 182 mm.

321 031 000
Upper bracket for
Mercedes A, B, C, E Class.

321 034 000
Mercedes E-Class bracket.



Springs



PORSCHE - VW
321 035 000

Porsche Cayenne and VW Tuareg bracket.



Springs



FERRARI
321 006 000

Special set of brackets suitable for all Ferrari models (old and new ones)

This special kit allows to adjust the position of the ring nut on Ferrari shock-absorbers

Springs



CHRYSLER
321 005 000

Special vice suitable for Chrysler Voyager models

This special kit allows to assemble and disassemble shock-absorber holding from the strut

321 042 000



Pneumatic machine for assembling and disassembling shock absorbers, specific for ARMOUR-PLATED VEICHLES.

Machine Dimensions: 650 x 400 x 1400 mm.
Packaging Dimensions: 520 x 300 x 1400 mm.
Machine weight: 70 Kg.
Alimentation: Air pressure min 6 bar., max 10 bar
Power: 10 bar=2.452 Kg.
Cylinder stroke: 420 mm.

ALS-Auto Levelling System

The two auto levelling upper arms allow to work easily both on conical and misaligned springs.

Cylinder: Stroke

It is possible to use this auto levelling machine also in case of long shock absorbers thanks to its 420 mm stroke.

Cylinder: Power

With a working pressure of 10 bar the machine exerts a compression force at 2.452 kg without loosing power.

Aluminium Technology

The cylinder is made in light alloy and nylon resin with fibreglass avoiding consequently the corrosion and the oxidation of the parts of the machine.

Safety fastening system

The machine can lock the shock absorber strut with a strong specific Vice.

Safety Valve & Safety Guard

The drive valve can function only when the machine is connected to the compressed air system. Consequently the machine can be disconnected while the spring is compressed without dangers assuring the maximum safety. The machine was designed in compliance with the 98/37/CE Machine Directives. The protection permit to work freely and in safety.

Tools Rack

The machine is equipped with a practical and steady tools rack.

Dimensions

Easy and quick to place, to move and to mount. It needs only to be connected to the air system.

CE approved machine in compliance with 98/37/CE (Machine Directive)



EXTRA HEAVY DUTY

Springs



Spirals

**321 011 000**

Hydraulic spring compressor suitable to press easily and quickly all type of shock-absorbers, even conical springs, from d.78 mm.to d.205 mm. Accessories supplied: pair of brackets for d. 78 mm. to d. 130 (for Mercedes cars), pair of brackets for d. 105 mm. to d. 182. Optional: pair of brackets for d. 125 mm. to d. 205, pair of special brackets for C 15 Citroen and Peugeot Break.

Premimolle idraulico. Consente la compressione di qualunque tipo di molla ammortizzatori da d. 78 mm. a d. 205 mm., anche conica, garantendo all'utilizzatore un lavoro rapido e agevole. Accessori in dotazione: coppia staffe da d. 78 mm. a d. 130 (speciali Mercedes), coppia staffe da d. 105 mm. a d. 182. Optional: coppia staffe da d. 125 mm. a d. 205, coppia staffe speciali C 15 Citroen e Peugeot Break.

Included**321 016 000** Brackets d. 105 - 185 mm. (2 PZ.)**321 002 000** Brackets d. 78 - 130 mm. (2 PZ.)

Spirals

321 003 004



321 001 000

On request**321 003 004**

Brackets model "B" from Ø 125 mm. to Ø 205 mm. (2 pz.)

**321 001 000**

Blocking vice for shock absorbers.

Spirals

**320 010 000**

This manual spring compressor allows the compression of the spring directly on the car. The strut can be removed without dismounting the bearing housing.

Coppia premimolle manuale, pratico e veloce permette di comprimere tutti i tipi di McPherson.



Spirals

**321 036 000**

Universal spring compressor heavy duty version, for vans, commercial vehicles and heavy duty springs.

Coppia premimolle manuale, versione potenziata, universale per veicoli commerciali e molle rinforzate.

314 002 000



Air operated Engine Hoist

Packaging Dimensions: 110 x 300 x 1520 mm.
 Machine weight: 20 Kg.
 Alimentation: Air pressure min 6 bar., max 8 bar
 Capacity: 6 bar= 301 Kgf., 8 bar=400 Kgf.
 Supports' distance: min. 850 mm. Max. 1460 mm.

Engine pneumatic hoist. It is the first pneumatic hoist for engines. It is so simple to use that the operator with the vehicle raised may position the engine without effort and with the maximum precision, using the special remote control. It should be positioned on the wheel arches, adjusting the length by means of the appropriate side arms. Once these arms are locked in position, you just have to attach the chain to any part of the engine, depending on the work to be done. It is designed to fit on the wheel arch of any type of vehicle. Designed for servicing: gearbox, clutch, valve timing, replacement of engine mountings, engine oil seals, and bodywork.

CE approved machine in compliance with 98/37/CE (Machine Directive)

Engine-gear box lifter



Manual hoist for engine.

314 012 000

Supports' distance: min. 700 mm. Max. 1480 mm.
 Capacity: 330 Kg.

314 012 015

Supports' distance: min. 700 mm. Max. 1720 mm.
 Capacity: 330 Kg.

It should be positioned on the wheel arches, adjusting the length by means of the appropriate side arms. Once these arms are locked in position, you just have to attach the two chain to any part of the engine, depending on the work to be done. It is designed to fit on the wheel arch of any type of vehicle thanks to the possibility of incination of the side supports. Designed for servicing: gearbox, clutch, valve timing, replacement of engine mountings, engine oil seals, and bodywork.

Engine-gear box lifter



319 001 000

To use with 314 002 000 - 314 012 000 - 314 012 015.

Brackets essential when using a pneumatic engine hoist on plastic wheel arches (e.g. Fiat, Kia, etc.). Positioning the brackets 319 001 000 between shock absorber cap and chassis member it allows to have a strong and safe support surface.

Engine-gear box lifter



Hubs and Bearings

320 002 000

Plastic box complete with hub pullers for spacers and bearings.

Cassetta in plastica 7 pezzi distanziali per cuscinetti e mozzi.

323 000 000

Spacer to extract-insert Renault bearings.

Distanziale per estrarre e introdurre cuscinetti Renault.

323 001 000

Spacer to extract-insert Peugeot 106 bearings.

Distanziale per estrarre e introdurre cuscinetti Peugeot 106.

323 002 000

Spacer to extract-insert Fiat , VW Golf, Opel Corsa and Astra bearings.

Distanziale per estrarre e introdurre cuscinetti Fiat e VW Golf, Opel Corsa, Astra.

323 003 000

Spacer to extract-insert Citroen bearings.

Distanziale per estrarre e introdurre cuscinetti Citroen.

323 004 000

Spacer to extract-insert Peugeot 205 bearings.

Distanziale per estrarre e introdurre cuscinetti Peugeot 205.

323 005 000

Spacer to extract-insert Renault, Fiat, VW , Peugeot, Alfa, Lancia, Opel hubs.

Distanziale per estrarre mozzi Renault, Fiat, VW, Peugeot, Alfa, Lancia, Opel.

323 006 000

Sp to extract insert Ford Mondeo, Escort, Fiesta, Peugeot e off roads hubs.

Distanziali per estrazione mozzi Ford Mondeo, Escort, Fiesta, Peugeot e fuoristrada.



Hubs and Bearings

320 004 000

Plastic box complete with spacers to extract-insert bearings.

Cassetta in plastica 3 pezzi distenziali per cuscinetti.

323 008 000

Spacer to extract-insert Renault Laguna bearings.

Distanziale per estrarre e introdurre cuscinetti Renault Laguna.

323 010 000

Spacer to extract-insert Peugeot 206 bearings.

Distanziale per estrarre e introdurre cuscinetti Peugeot 206.

323 013 000

Spacer to extract-insert VW Golf IV-Audi A3 bearings.

Distanziale per estrarre e introdurre cuscinetti VW Golf IV-Audi A3.



320 011 000

Complete set for mounting and dismounting bearing and hub on

Models: Fiat Ducato, Citroen Jumper, Peugeot Boxter

Hubs and Bearings**320 015 000**

Set of tools for removing and inserting hubs and bearings complete with:

Cassetta per la rimozione e l'inserimento dei cuscinetti e dei mozzi composta da:

- 323 000 000 Bearings: Renault
- 323 002 000 Bearings: Fiat, VW
- 323 003 000 Bearings: Citroen
- 323 005 000 Hubs: Renault, Peugeot, Fiat, Alfa, Lancia
- 323 006 000 Hubs: Peugeot, Ford e Fuoristrada
- 323 009 000 Hubs: Renault Laguna c/abs
- 323 010 000 Bearings: Peugeot 206
- 323 013 000 Bearings: VW-Audi

Hubs and Bearings**320 016 000**

Set of tools for removing and inserting hubs and bearings complete with:

Cassetta per la rimozione e l'inserimento dei cuscinetti e dei mozzi composta da:

- 323 000 000 Bearings: Renault
- 323 003 000 Bearings: Citroen
- 323 005 000 Hubs: Renault, Peugeot, Fiat, Alfa, Lancia
- 323 006 000 Hubs: Peugeot, Ford and Off-Roads
- 323 009 000 Hubs: Renault Laguna with ABS
- 323 010 000 Bearings: Peugeot 206

Hubs and Bearings

Hubs and Bearings



320 003 000

Set of tools for the replacement of inner ring bearings.

Application:

VW, Audi, Bmw, Ford, Fiat, Mercedes, Opel, Renault, Peugeot, Volvo, etc.

- Extractor tool \varnothing 40-45 mm.,
- Extractor tool \varnothing 45-51 mm.,
- Extractor tool \varnothing 50-55 mm.,
- Extractor tool \varnothing 55-61 mm.,
- Lock nut wrench \varnothing 83 mm.,
- Wrench \varnothing 59,5 mm.,
- Body extractor.



On request

323 016 014

Special small size clip to use with code 320 003 000.

Extractor tool \varnothing 35/40.



CV Joint

320 008 000

Universal complete set for replacing synchronizing shaft and CV joint.

Cassetta universale completa estrattore per giunti omocinetic.

TECHNICAL DATA

- Centre distance: min. 98 mm.
- Centre distance: max. 130 mm.
- Holes: N. 3 ==> 6
- Screws: M12 ==> m14



311 026 025

Universal kit suitable for replacing synchronizing shafts and cv joints, with slide hammer.

TECHNICAL DATA

Centre distance: min. 98 mm.
 Centre distance: max. 130 mm.
 Holes: N. 3 => 6
 Screws: M12=> m14



CV Joint



323 000 000

Spacer to extract-insert the bearing-Renault.

Distanziale per estrarre e introdurre cuscinetti Renault.



Hubs and Bearings



323 001 000

Spacer to extract-insert Peugeot 106 bearings.

Distanziale per estrarre e introdurre cuscinetti Peugeot 106.



Hubs and Bearings



323 002 000

Spacer to extract-insert Fiat bearing.

Distanziale per estrarre e introdurre cuscinetti Fiat.

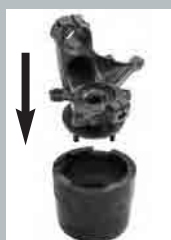

Hubs and Bearings



Hubs and Bearings



323 003 000

Spacer to extract-insert the bearing-Citroen.

Distanziale per estrarre e introdurre cuscinetti Citroen.



Hubs and Bearings



323 004 000

Spacer to extract-insert Peugeot 205 bearings.

Distanziale per estrarre e introdurre cuscinetti Peugeot 205.

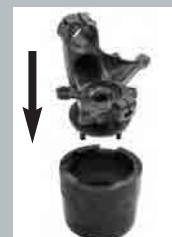

Hubs and Bearings



323 005 000

Hub puller Renault, Fiat, VW, Peugeot, Alfa, Lancia, Opel. Use this hub puller together with mod. 323 006 000.

Distanziale per estrazione mozzi Renault, Fiat, VW, Peugeot, Alfa, Lancia, Opel. Questo distanziale si deve utilizzare in abbinamento all' art. 323 006 000.

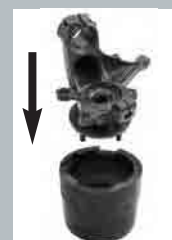

Hubs and Bearings



323 006 000

Ford Mondeo, Escort, Fiesta, Peugeot and off road hub puller.

Distanziale per estrazione mozzi Ford Mondeo, Escort, Fiesta, Peugeot e fuoristrada.

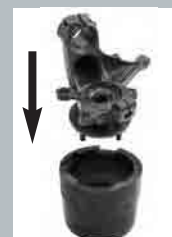

Hubs and Bearings



323 007 000

Kit for dismounting bearings. It makes easier to insert bearing race and seals without damages to race and axle housing. This set includes three sizes to fit most standard wheel bearings.

Kit tampone e rondelle per estrazione cuscinetti: rende più agevole e facile l'estrazione e l'inserimento senza danneggiamenti del cuscinetto e della sua sede.



323 008 000

Plate for disassembling ball bearings and gears.

Piastra per pressa per estrarre cuscinetti.

Hubs and Bearings**323 009 000**

Spacer to extract-insert Renault bearings.

Distanziale per estrarre e introdurre cuscinetti Renault Laguna.

Hubs and Bearings**323 010 000**

Bearings extractor for Peugeot 205 -206.

Distanziale per estrazione cuscinetti Peugeot 205 - 206.

Hubs and Bearings**323 011 000**

Hubs extractor for Renault Trafic.

Distanziale per estrazione mozzi Renault Trafic.

Hubs and Bearings**323 012 000**

Bearings extractor for Renault Trafic.

Distanziale per estrazione cuscinetti Renault Trafic.

Hubs and Bearings

Hubs and Bearings



323 013 000

Spacer to extract-insert VW Golf IV-Audi/ A4 bearings.

Distanziale per estrarre e introdurre cuscinetti VW Golf IV-Audi /A4.

Hubs and Bearings



323 014 000

Kit for removing hubs and synchronizing shafts suitable for VW-Audi models.

Estrattore per mozzi e giunti omocinetici montati su modelli VW-Audi

Hubs and Bearings



323 018 000

Special torx-E14 key suitable for hubs removing on Smart models.

Chiave a bussola torx-E14 adattabile allo smontaggio dei mozzi sui veicoli Smart.



Hubs and Bearings



323 019 000

Special XZN 18mm. key suitable for hubs removing on VW Golf models, V serie.

Chiave XZN 18 mm. adattabile allo smontaggio dei mozzi sui veicoli VW Golf, serie V.

Hubs and Bearings



323 022 000

Spacer for dismounting rear hubs on Renault models.

Chiave per smontaggio mozzi posteriori modelli Renault.

330 003 000

Complete box made of 25 pcs. suitable for floating and non floating brake capilers, both right and left screw.



Brake Service Tools



332 001 000

Universal pressure and wind back tool for pressing back brake caliper pistons in fully floating brake calipers, both connected or not to handbrake mechanism.

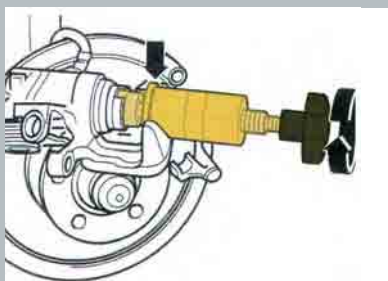

Brake Service Tools



330 001 000

Universal pressure and wind back tool for pressing back brake caliper pistons in floating brake calipers, suitable for VW-Audi-Seat-Skoda, etc.

Attrezzo per arretrare pistoncini freni delle pinze aperte, adattabile a tutta la gamma VW-Audi-Seat-Skoda, ecc.

Brake Service Tools



332 007 000

Special wind back tool for pressing back brake caliper pistons mounted on Fiat models.

Kit per arretrare i pistoncini freni adattabile ai modelli Fiat

Brake Service Tools





351 000 000

Very versatile precision standard headlight tester, to use with all types of vehicles. The optical box is adjustable, with graduated analogic lux encoder.

Provaferi standard di precisione, molto versatile e ideale per tutti i tipi di veicoli, puntamento ottico a traguardo con luxometro analogico graduato.



351 002 000

Electronic headlight tester with interface RS232, that allows the connections to local or networked PC with fitting management softwares. Adjustable optical box with precise internal micro level. This article is equipped with an electronic encoder to control the inclination of the head lamp. Mirror optical positioning. Serial interface ECT with digital lux encoder 3 1/2 digit. Approved by the ministry of transport mctc-net.

Provaferi elettronico con interfaccia seriale RS232 per il collegamento a PC locali o in rete, con appositi programmi di gestione. Camera ottica orientabile con micro livella di precisione all'interno e sistema elettronico di ricerca automatica dell'esatta inclinazione del faro. Puntamento ottico a specchio, interfaccia seriale ECT con luxometro digitale 3 1/2 digit. Omologato dal ministero dei trasporti mctc-net.

351 006 000

Electronic headlight tester with interface RS232, that allows the connections to local or networked PC with fitting management softwares. Adjustable optical box with precise internal micro level. This article is equipped with an electronic encoder to control the inclination of the head lamp. Mirror optical positioning. Serial interface ECT with digital lux encoder 3 1/2 digit.

Provaferi elettronico con interfaccia seriale RS232 per il collegamento a PC locali o in rete, con appositi programmi di gestione. Camera ottica orientabile con micro livella di precisione all'interno e sistema elettronico di ricerca automatica dell'esatta inclinazione del faro. Puntamento ottico a specchio, interfaccia seriale ECT con luxometro digitale 3 1/2 digit.

351 003 000

Headlights tester cheap and easy to use, this headlights tester guarantees a good precision. The inclination panel is fix and equipped with a percentage inclination engraved scale. The optical box is adjustable, with precise analogic coloured 3F lux encoder.

Provaferi semplice ed economico ma di buona precisione. Il pannello delle pendenze è fisso con scala serigrafata delle percentuali di inclinazione. Dispone di un puntamento ottico a traguardo con luxometro analogico 3F colorato.

**351 004 000 - 351 005 000 - 351 007 000**

Electronic headlights tester with serial interface RS 232, that allows the transmission to the PC of the data of inclination and measure of the light in lux/25 mt K cand. and K lux/1mt. 351 004 000 is equipped with an electronic encoder to control the inclination of the head lamp from 0% to 4%. The version 351 005 000 comes with an engine in continous power, to move the inclination panel with a maximun error of 0,05% of the inclination. The optical box is adjustable, with precise internal micro level. It is also available on rails, with the only substitution of the back wheels. Mirror optical positioning g. Serial interface digital lux encoder.

351 004 000 Mirror optical positioning - Serial interface digital lux encoder.

351 005 000 Mirror optical positioning - Serial interface encoder + engine digital lux.

351 007 000 Mirror optical positioning - Serial interface digital lux encoder. Approved by the ministry of transport.





Oil Filters

310 001 000

Complete set of wrench for dismounting oil filters.

Set completo di chiavi per lo smontaggio filtri olio.

1 Filter wrench for VW-AUDI TDI, NISSAN models.

2 Filter wrench for RENAULT models.

3 Filter wrench for FIAT PUNTO 1.2, RENAULT 1.2 from '98.

4 Filter wrench for VW-AUDI cartridge filter version.

5 Filter wrench for FORD ZETEC, OPEL models.

6 Filter wrench for FIAT Common Rail 125 HP. models.

7 Filter wrench for FIAT Common Rail 1.9-2.4 JTD (old models).

8 Filter wrench for FIAT PUNTO gasoline engines.



Oil Filters

310 001 001

Oil filter wrench cup for VW-AUDI TDI, NISSAN models.

Type 66,5 mm.

Flutes 45.



Oil Filters

310 001 002

Oil filter wrench cup for RENAULT models.

Type 87 mm.

Flutes 18.

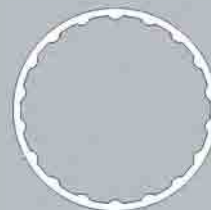

Oil Filters

310 001 003

Oil filter wrench cup for FIAT PUNTO 1.2, RENAULT 1.2 from '98.

Type 66,5 mm.

Flutes 6.



310 001 004

Oil filter wrench cup for VW-AUDI CARTRIDGE FILTER.

Type 74,4 mm.
Flutes 14.

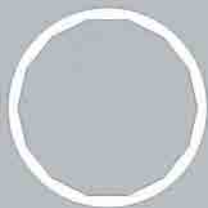

Oil Filters



310 001 005

Oil filter wrench cup for FORD ZETEC, OPEL models.

Type 74 mm.
Flutes 15.

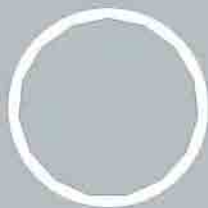

Oil Filters



310 001 006

Oil filter wrench cup for FIAT COMMON RAIL 125 HP. models.

Type 92 mm.
Flutes 10.

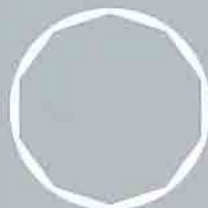

Oil Filters



310 001 007

Oil filter wrench cup for FIAT COMMON RAIL 1.9-2.4 JTD (OLD MODELS).

Type 76,5 mm.
Flutes 8.

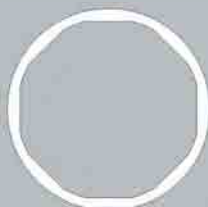

Oil Filters



310 001 008

Oil filter wrench cup for FIAT PUNTO GASOLINE ENGINES.

Type 64 mm.
Flutes 14.

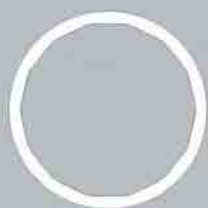

Oil Filters





Oil Filters

312 021 000

Oil filter wrench cup for Fiat Ducato models.

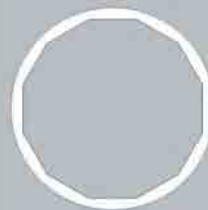
Type 91 mm.**Flutes** 12.

Oil Filters

310 001 010Oil filter wrench cup for: **Mercedes:** All Purflux LS 918 filter models.**Renault:** Megane, Laguna, Espace I+II+III, Twingo, Clio, Kangoo,R5. **Ford:** 1.8 l diesel

and with motorcraft

filter. **Peugeot:** all

Purflux filter models.

Fiat: Ducato, Scudo,

Ulisse, Stilo, Multipla,

Doblò all JTD

models.

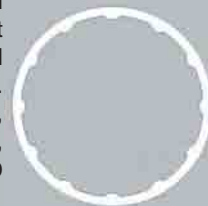
Type 76,8 mm.**Flutes** 12.

Oil Filters

310 001 011

Oil filter wrench cup for Renault: 1.2 & 1.4 gasoline engines (Twingo, Clio, Kangoo, Modus, Mègane, Scenic, etc.).

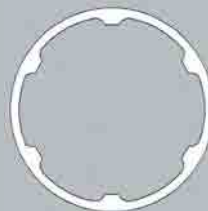
Type 66,6 mm.**Flutes** 6.

Oil Filters

310 001 012

Oil filter wrench cup for Renault: 1.5, 1.9 & 2.2 DCI diesel engines (Clio, Kangoo, Modus, Mègane, Scenic, etc.).

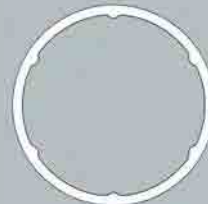
Type 96,4 mm.**Flutes** 6.

Oil Filters

310 001 013

Oil filter wrench cup for Alfa Romeo MultiJet models.

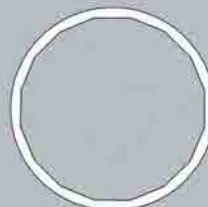
Type 75,3 mm.**Flutes** 16.

312 047 000

Oil filter wrench cup for Renault: Trafic & Master diesel engines.

Type 107,7 mm.
Flutes 18.

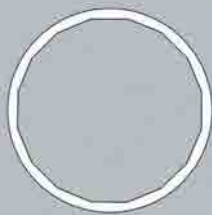

Oil Filters



312 044 000

Couple of filter wrenches for gasoline engine.

Set di chiavi per filtri motori benzina.

Oil filter wrench cup for FIAT PUNTO GASOLINE ENGINES.

Oil filter wrench cup for

Mercedes: All Purflux LS 918 filter models.

Renault: Megane, Laguna , Espace I+II+III, Twingo, Clio, Kangoo, R5.

Ford: 1.8 l diesel and with motorcraft filter.

Peugeot: all Purflux filter models.

Fiat: Ducato, Scudo, Ulisse, Stilo, Multipla, Doblò all JTD models.

Oil Filters



312 046 000

Oil filter wrench cup for OPEL diesel common rail 1.3 and 1.9 models.



Oil Filters



312 000 000

Universal pressed steel jointed chain tools for oil filters with extendable handle.

Chiave a catena snodata per filtri olio con manico prolungabile.

Oil Filters



Oil Filters

**312 001 000**

Universal ribbon tool of printed steel for oil filter d. 70/110 mm.

Chiave universale a nastro in acciaio stampato per filtri d. 70/110 mm.

Oil Filters

**312 002 000**

Universal ribbon tool of printed steel for oil filter d. 110/145 mm.

Chiave universale a nastro in acciaio stampato per filtri d. 110/145 mm.

Oil Filters

**312 003 000**

Universal chain tool of printed steel for oil filter d. 70/110 mm.

Chiave universale a catena in acciaio stampato per filtri d. 70/110 mm.

Oil Filters

**312 004 000**

Universal chain tool of printed steel for oil filter d. 110/145 mm.

Chiave universale a catena in acciaio stampato per filtri d. 110/145 mm.

312 005 000

Universal casehardened steel T tool for engine plugs, 8-10 mm. square, 12 mm. hex.
 Chiave univiversale T tappi coppe olio motori 8 mm.quadro, 10 mm.quadro, 12 mm. esagonale.

312 006 000

Universal casehardened steel T tool for engine plugs, 8-10-12 mm. hex.
 Chiave univiversale T tappi coppe olio motori impugnatura plast. 8-10-12 esagonale

Oil Filters



312 039 000

Multijet filters extractor.

Attrezzo per filtri multijet verniciato con scatola.

Brand Model Engine

Fiat:

Punto, Panda, Idea, Stylo, Doblo
 Engine: 1.3 Multijet 16v

Lancia:

Ypsilon, Musa
 Engine: 1.3 Multijet 16v

Opel:

Corsa, Agila
 Engine: 1.3 CDTI

Suzuki:

Ignis, Vagon R+
 Engine: 1.3 DDiS 16v

Oil Filters



412 001 000

Special filter wrench suitable for Piaggio engines. For assembling and disassembling Piaggio filters mod.829405.



Oil Filters





injectors

311 002 000

Special injector extractor suitable for JTD Diesel engines mounted on Fiat, Alfa, Lancia, Opel, Saab, Suzuki models. It is equipped with 4 adjustable feet.

Estrattore per iniettori adattabile per motori Diesel JTD montati su Fiat, Alfa, Lancia, Opel, Saab, Suzuki.

Models: Fiat, Alfa, Opel, Saab, Suzuki.

Engines: JTD



injectors

311 023 000

Special Injector Extractor Set suitable for dismounting Mercedes injectors on CDI engines. Designed for difficult working in narrow places.

Set speciale per lo smontaggio degli iniettori montati sui motori Mercedes CDI.

Models: Mercedes.

Engines: CDI



injectors

311 032 000

Special injector extractor suitable for Mercedes and Bosch models, complete with a Socket for dismounting electrical connection.

Estrattore per iniettori adattabile per modelli Mercedes, Bosch, completo di bussola per smontaggio connessione elettrica.

Models:

Mercedes: Sprinter, Vito, Viano, Vario.

Engines: CDI

Included Components

1



Extractor for injectors

2



Socket for electrical connection

311 026 000

Universal complete set suitable for removing Bosch, Delphi: Mercedes, Volvo, Ford, Renault, Kia, trucks and general injectors.

Cassetta universale per l'estrazione degli iniettori.

Models: Mercedes, Volvo, Ford, Renault, Kia, Trucks.

Included components

- | | | |
|---|---|-------------------------|
| 1 |  | Body-tamper |
| 2 |  | M18 long handle 450 mm. |
| 3 |  | M18 long handle 350 mm. |
| 4 |  | Upper handle |
| 5 |  | Adaptor M18-M22 |
| 6 |  | M18 "Fork" extractor |
| 7 |  | Threaded insert |
| 8 |  | M18 Socket for Delphi |
| 9 |  | M22 Socket for Bosch |

injectors

**311 026 018**

Universal joint to apply to slide hammer (code 311 026 000) in order to operate in case of few space condition.

Giunto snodato da utilizzare con estrattore a battitoio (codice 311 026 000).

injectors

**311 026 031**

M18 socket suitable for Opel 2.2 Diesel models (to apply to slide hammer code 311 026 000).

Bussola M18 per iniettori montati su modelli Opel (da utilizzare con estrattore a battitoio codice 311 026 000).

injectors





injectors

311 062 000

Special kit suitable for removing Siemens injectors on diesel engines (to apply to slide hammer code 311 026 000)

Engines: 1.4 - 2.0 - 2.2 diesel
Models: Peugeot, Citroen, Ford, Toyota
Components:
 311026032 - Special Fork for Siemens injectors
 311026033 - Special Socket M18-M25
 311026034 - Locking nut



injectors

311 049 000

Complete set for removing Mercedes CDI injectors, specially designed for A & B - Class. This tool enable to remove two injectors simultaneously without dismantling valves cover. Include also GOVONI code 311 035 012.

Models:
 168 Mercedes A class (old model, up to 2004), 169 (245 B) Mercedes A class (new model, from 2004), Mercedes B class.

Engines: 668, 640



injectors

311 055 000

Complete set for removing BMW Common Rail injectors, specially designed for M47TU, M57 and M57TU engines. This kit allows the removal of tightly fit injectors nozzles without having to remove the cylinder head.

Engines:
 Bmw Common-Rail M47TU, M57 and M57TU



311 056 000

Complete set for removing PSA HDI injection nozzles. This kit allows the removal of tightly fit injectors nozzles without having to remove the cylinder head. This kit is made of a pulling bridge that fits perfectly on PSA cylinder head, and with a special screw system allows a fast and easy nozzle removal.

Engines: PSA 2.0 (110, 135 HP) HDI DW10 and DW12 engines

Injectors



311 050 000

Special injector extractor for injector Pump system. Complete with handle and slide hammer. Specially designed for Injector Pump system.

Models: VW injector Pump System.

Engines: TDI-PD

Injectors



311 050 006

Special injector extractor suitable for Volkswagen, Audi, Seat and Skoda models. Complete with handle, slide hammer and Special vice clip. Specially designed for Injector Pump system.

Models: VW injector Pump System and traditional injectors.

Engines: TDI-PD

Injectors





Timing tools

311 047 000

Set of tools suitable for Injectors seat cleaning, complete with:
 311047013 - Special tool for injector seat resurfacing
 311047003 - Special tool for injector edge resurfacing
 311047005 - Special blowing tool (M10 + M8 thread)
 311047008 - 17 mm. combination wrench

Models: Mercedes.

Engines: CDI

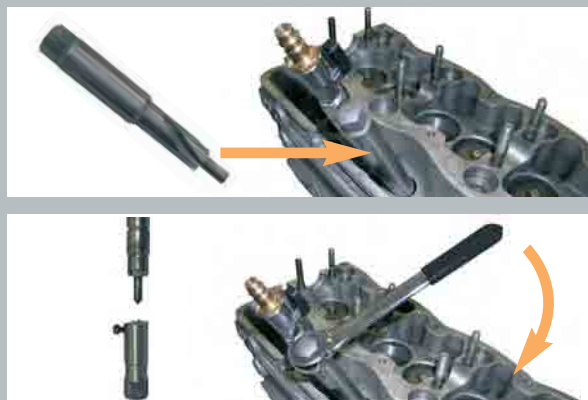

Timing tools

311 047 014

Set of tools suitable for Injectors seat cleaning, complete with:

311047013 - Special tool for injector seat resurfacing (Bosch models)
 311063000 - Special tool for injector seat resurfacing (Siemens models)
 311047003 - Special tool for injector edge resurfacing
 311047005 - Special blowing tool (M10 + M8 thread)
 311047008 - 17 mm. combination wrench

Models: Mercedes.

Engines: CDI

Models: Peugeot, Citroen, Ford, Toyota

Engines: 1.4 - 2.0 - 2.2 diesel



Timing tools

311 063 000

Special tool for injector seat resurfacing

Models: Peugeot, Citroen, Ford, Toyota.

Engines: 1.4 - 2.0 - 2.2 diesel.

311 051 000

Special injector extractor suitable for new generation Trucks that mount Injector-Pump system, and for traditional truck injectors. (Volvo, Scania, Mercedes, Man, Renault, Iveco, etc.).

Speciale estrattore per iniettori adattabile alla nuova generazione Veicoli pesanti autotrazione, che montano il sistema di iniettori-pompa, ed anche agli iniettori tradizionali. (Volvo, Scania, Mercedes, Man, Renault, Iveco, etc.)



Injectors



720 015 000

Special socket suitable to remove injectors electrical connection.
=> 29 mm. polygonal.



Speciale bussola per la rimozione della connessione elettrica degli iniettori.
=> 29 mm. poligonale.



Injectors



311 026 014

Special tool suitable to remove the injector spindle.
=> 10 mm.HEX



Attrezzo speciale per la rimozione e lo smontaggio dell'elettrodo degli iniettori.
=> 10 mm.

Injectors



311 004 000

Dialer support for injection pump.

Supporto comparatore per pompa iniezione.

Injectors



Injector Tools



311 031 000

Complete set for removing M10 thread glow plugs.

Cassetta completa per la rimozione delle candele con filetto M10.

Included Components

311 031 018	Ratchet Wrench
311 031 011	Ø 9-5,5 mm. double diameters bit, piloted drill bit, with extension.
311 031 012	Puller
311 031 003	
311 030 003	
331 031 009	10x1 threaded male
311 031 010	1/4" threaded male
311 031 007	E10 torx socket
311 031 005	Ø 6 mm. guide (2 pcs.)
311 031 004	1/4" threaded insert (2 pcs.)

Injector Tools



311 031 017

Complete set for removing M10 + M8 thread glow plugs

Cassetta completa per la rimozione delle candele con filetto M10 e M8.

Includes same components as code 311 031 000 with in additional:

311031015 - M8x1 threaded male

311031014 - Ø7-5,5 mm. piloted drill bit



Injector Tools



311 031 019

Dummy Injector - Bosch version

Suitable for blowing air into injector seat during broken glow plugs replacement operations.

772 001 000

Special kit to restore threads on aluminium engine heads. Suitable for restoring fixing threads for injector support on diesel engines (Mercedes models, etc.)

Kit per ripristino filetti M6 sulle testate motore in alluminio. Adatto per ripristinare i filetti di fissaggio supporto iniettori dei motori diesel (modelli Mercedes, etc.).

Including:

- Drill bit dia.9 mm.
- Special tool for screwing threaded inserts
- M6x60 hex head bolt
- n.10 threaded inserts

772 001 002

Spare part kit including n.10 threaded inserts



General repairs



311 001 000

Special plier with specific grip for dismantling automatic fuel connection.

Pinza per smontaggio innesti automatici tubi benzina.

General repairs



311 037 000

Special set of clips suitable for dismantling Diesel filter connections. Specially designed for Multijet engines.

Set composto da due pinze per lo smontaggio dei raccordi filtri gasolio

Models Fiat: Punto, Panda, Idea, Stylo, Doblo
Engines: 1.3 Multijet 16v

Models Lancia: Ypsilon, Musa
Engines: 1.3 Multijet 16v

Models Opel: Corsa, Agila
Engines: 1.3 CDTI

Models Suzuki: Ignis, Vagon R+
Engines: 1.3 DDiS 16v

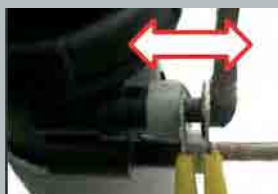

General repairs





General repairs

311 005 000

Wrench for dismounting Bosch phase alternator.

Chiave per smontaggio e rimontaggio alternatore di fase Bosch.



General repairs

311 043 000

Wrench suitable for dismounting Delphi phase alternators.

Chiave per smontaggio alternatori di fase Delphi.



General repairs

313 034 000

Adjustable wrench for locking and rotating pulleys.

Chiave per il bloccaggio/rotazione pulegge regolabile.

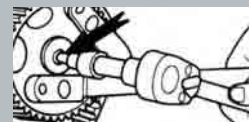

General repairs

313 036 000

Universal belt tensioner d. 5,6,8 mm.

Chiave tendicinghia universale d. 5,6,8 mm.



General repairs

313 146 000

Universal pulleys extractor.

Attrezzo speciale universale estrattore per pulegge.



General repairs

313 182 000

Special kit equipped with 5 thin and plate polygonal wrenches with extension for double use. Suitable for dismounting timing pulleys, auxiliary pulleys and belt stretchers.

Kit composto da 5 chiavi poligonali piatte e sottili con prolunga per doppio utilizzo. Adattabili per lo smontaggio di pulegge distribuzione, organi ausiliari e tendicinghia.

Sizes: 13-15-16-17-19 mm.

317 001 000

Special tool for replacing oxygen sensor – 22 mm.
Bussola per smontaggio sonda lambda – 22 mm.

317 002 000

Special tool for replacing oxygen sensor – 20 mm.
Bussola per smontaggio sonda lambda – 20 mm.

General repairs



317 001 000



317 002 000

318 004 000

Special set of tools suitable mounting/dismounting SAC clutch.

Attrezzo speciale per il montaggio/smontaggio delle Frizini SAC.



General repairs



390 003 000

Carburetor float remover equipped with 5 series of extensions, that include also PSA and Renault models. It fits different diameters: min. 70, max. 170 mm.

Manina a 3 zampe per rimozione galleggiante con accessori. Dotazione standard: kit zampe plastificate L = 32 mm.



390 001 021



Standard extension

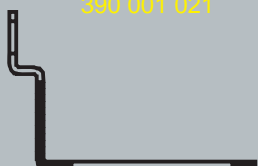

390 001 022



390 001 023



390 001 024

General repairs





General repairs

313 176 000

Adjustable extracting tool for Poli-V pulleys.

Technical data:
Pulley diameter: Min 50 mm. Max 180 mm.
Cog depth: 3,5 mm.



General repairs

313 180 000

Universal flywheel locking tool. Totally adjustable, thanks to its several holes can be regulated on different positions and angles.

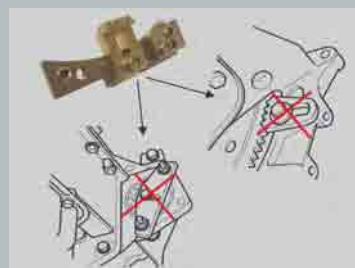

General repairs

314 003 000

Adjustable homing at full expansion for trucks for cylinder d. 60-260 mm. length of the stones 127 mm.

Spare: 314 004 000

Serie 3 stones with support - Length 127 mm.

314 005 000

Adjustable homing at full expansion for cars for cylinder d. 50-160 mm. length of the stones 100 mm.

Spare: 314 006 000

Serie 3 stones with support - Length 100 mm.



General repairs

314 009 000

"Mini" homing for brakes cylinders 3 stones, for cylinders d. 20-80 mm. and length of the stones 35 mm.

Spare: 314 010 000

Serie 3 stones with support - Length 35 mm.

414 000 000

Adjustable homing at full expansion for motorbike. Easy working apply the device to a common hand or column drill at the speed of 1500-2000 rpm. Insert the arms into the hole, adjusting pression according to your neccesity. During the work the arms inside the cylinder compress the sectors againts the side of the cylinder, centering themselves automatically. A flexible bar inserted in the support gives a working possibility to all the surface even if it is conic. The durability of the operation must be rapported to the speed of the drill. It is raccomandato to lubricate always the honing stone and surface.

For motorbike cylinder d. 30-90 mm. lenght of the stones 100 mm.

Spare: 414 001 000

Serie 3 stones with support - Lenght 100 mm.

General repairs**384 000 000**

Locking wrench for metallic clamps between rubber caps and cardan joints.

Chiave per serraggio delle fascette metalliche fra cuffie in gomma e giunti omocinetic.

General repairs**310 076 000**

Extractor for Bosch-Magneti Marelli and Delphi alternators with connections.

Kit per smontaggio alternatori Bosch-Marelli e Delphi con attacchi.

310084001 TORX 10 L=110 MM. connection 1/2"

310084002 TORX 50 L=110 MM. connection 1/2"

310084003 Wrench XZN for BOSCH alternators Ø13 mm-22 mm.

310084004 Wrench XZN for BOSCH alternators Ø12 mm-17 mm.

311005000 Wrench suitable for Bosch-Marelli alternators

311043000 Wrench suitable for Delphi alternators

General repairs

Steering System

**385 001 000**

Special universal extractor for steering system inner hole d. 43,2 mm. - 20,25 mm.

Estrattore universale per i braccetti scatola sterzo, diametro interno 43,2 mm - 20,25 mm



Steering System

**385 004 000**

Special universal extractor for steering system, suitable for vans, commercial vehicles, cars inner hole d. 45,2 mm.- 32,25 mm.

Estrattore speciale per i braccetti scatola sterzo, adattabile ai veicoli commerciali, diametro interno 45,2 mm - 32,25 mm.



Steering System

**385 003 000**

Special tool suitable for extracting ball joints.

Estrattore speciale adattabile alla rimozione delle testine oscillanti.



340 001 000

Set for adjusting sheet without painting made up of lifting tool, plastic adaptors, glue.

Kit carrozzeria composto da pinza regolabile per il tiraggio lamiera, set di ventose e stick di colla a caldo.

Body Tools**340 002 000**

Special set for fixing sheet panel during the whelding operations.

Set carrozzeria con pinza per il fissaggio durante le operazioni di saldatura lamierati.

Body Tools**340 004 000**

Set for adjusting sheet without painting made up of: lifting tool, n. 30 plastic adaptors, n. 10 glue sticks, hammer, glue gun, alcohol, punch.

Master Kit per carrozzeria composto da: pinza tiraggio lamiera, 30 ventose in plastica, 10 stick colla a caldo, martello, pistola, punzone, alcol.

Body Tools



Body Tools

710 018 000

3-shelved trolley. Carrello 3 piani smontabile.

Model no.	A	B	H	Kg
	810	410	790	20

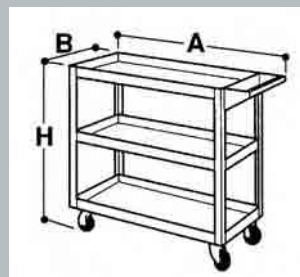

Body Tools

343 003 000

Heavy duty trolley with 6-station masking paper dispenser. Includes spring loaded cutter bar and masking tape dispenser on all stations. Automatically applies adhesive tape to edges of masking paper.

Distributore-porta rotoli per mascheratura, versione con ruote. Dotato di rulli che applicano automaticamente il nastro adesivo sul bordo della carta e molle con cutter su ogni postazione.

Rolls accepted

Dimensioni rotoli supportati:

17cm.-34 cm.-48 cm.-66 cm.-93 cm.-125 cm.



Body Tools

343 004 000

Wall-mounted masking paper dispenser made of galvanized and enamelled metal tubes. Automatically applies adhesive tape to edges of masking paper.

Distributore-porta rotoli per mascheratura, versione fissaggio a muro. Dotato di rulli che applicano automaticamente il nastro adesivo sul bordo della carta.

Rolls accepted

Dimensioni rotoli supportati:

33 cm.-64 cm.-105 cm.

343 002 00

Wall-mounted paper dispenser made of galvanized and enamelled metal tubes.

Distributore carta a muro in tubo metallico, zincato o smaltato.

Body Tools**343 000 000**

Floor-standing paper dispenser made of galvanized and enamelled metal tubes.

Distributore carta a terra in tubo metallico, zincato o smaltato.

Body Tools**343 001 000**

Floor-standing paper dispenser with wheels and bag-holder. Made of galvanized and enamelled metal tubes.

Distributore carta a terra con ruote e portasacchi in tubo metallico, zincato o smaltato.

Body Tools

Body Tools



Punch pliers for steel-sheet. It render easy and similar to the original the welding of sheet thanks to the hole that makes on the new part before the assembly (see operations on mudguards).

Pinze foralamiera. Rendono agevole e simile all'originale la saldatura dei lamierati grazie al foro che praticano sulla parte nuova prima del montaggio (vedi operazioni sui parafanghi ecc.).

344 005 000 hole d. mm. 8

344 004 000 hole d. mm. 6

344 003 000 hole d. mm. 5

344 002 000 hole d. mm. 4

344 000 000 hole d. mm. 3



Body Tools



344 007 000

Sheet bending pliers. This tool makes it possible to create an edge that allows you to achieve planarity between two superimposed steel sheets.

Pinza piegalamiera. Crea un bordo che permette di mantenere la linearità del piano sovrapponendo due lamierati.

Body Tools



345 001 000

Suitable for pre-forming and finishing door skins onto door frames. Also suitable for joining sheet material. Fitted with nylon pad to prevent panel deformation.

Pinza bordatrice per piegatura e finitura unione lamierati e pannelli-Renault. Dotata di battuata in nylon per proteggere e previene deformazioni.

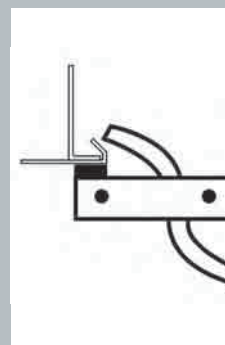

Body Tools



345 007 000

Wrench to remove door hinge on Fiat models.

Attrezzo per lo smontaggio delle spine cerniere e porte modelli Fiat.

344 008 000

Punch useful to assembly-disassembly doors-lock-Fiat models.

Pinza per lo smontaggio e rimontaggio delle serrature portiere, modelli Fiat.

Timing tools**342 001 000**

Toe dolly.

Tassello per carrozzeria.

Timing tools**349 003 000**

Tool for mounting and dismounting of external review mirror.

Chiave per lo smontaggio dello specchio esterno Fiat Punto.

Timing tools**341 001 000**

Special hammer for hail d.21 mm.
Martello per grandine d.21 mm.

341 002 000

Special hammer for hail d.18 mm.
Martello per grandine d.18 mm.

Timing tools**345 002 000**

Lock door remover suitable for Ford models.

Chiave per smontaggio serratura portiera Ford.

Timing tools**349 002 000**

Complete set for adjusting sheet – lever system.

Set per il tiraggio lamiera.

Timing tools

Tyres

360 000 000

Air operated tyre spreader.

Cylinder size: 40 mm.
 Max. tyre opening: 300 mm.
 Stroke: 170 mm.
 Power: 75 kgf (6 bar), 100 kgf (8 bar)
 Weight: 15 kg.

Tyre spreader for cars and commercial vehicles. Mounted with wall mounted bracket, it can rotate up to 360° in order to facilitate working operations. In no-working condition the machine can be closed to the wall saving space.

Divaricatore per pneumatici di autovetture e veicoli commerciali.

CE approved machine in compliance with 98/37/CE (Machine Directive)



Tyres

360 012 000

Portable pneumatic tyre spreader suitable for cars and commercial vehicles.

Cylinder size: 80 mm.
 Max. tyre opening: 400 mm.
 Stroke: 290 mm.
 Power: 301 kgf (6 bar)
 Power: 401 kgf (8 bar)
 Weight: 6,2 kg.

This new tyre spreader is portable and weights only 6,2 kg. It is equipped with a strong handle, that allows an easy and practical handling. The spreader opens out the tyre with a maximum width of 400 mm, consequently checking and working operations inside the tyre become really very easy and handy. The working power is granted by the pneumatic cylinder, that can reach an opening force of over 300 kg and it is adjustable using the 2 valves that control the opening and the closure of the stem. This tyre spreader is suitable for auto and commercial vehicles tyres.

CE approved machine in compliance with 98/37/CE (Machine Directive)



360 013 000

Pneumatic tyre spreader suitable for cars and commercial vehicles, equipped with pedestal and adjusting system.

Divericatore per pneumatici con funzionamento ad aria compressa, dotato di piedistallo e sistema di regolazione.

Cylinder size: 40 mm.
 Max. tyre opening: 300 mm.
 Stroke: 170 mm.
 Power: 75 kgf (6 bar), 100 kgf (8 bar)
 Weight: 18 kg.

CE approved machine in compliance with 98/37/CE (Machine Directive)

**Tyres****360 009 000**

Tyre regroover "Compact" 60-120 W.
 Rigatore per pneumatici "Compact" 60-120 W.

360 010 000

Tyre regroover "Compact" 80-140 W.
 Rigatore per pneumatici "Compact" 80-140 W.

Tyre regroover. The width of the cut groove varies from mm. 2 to 38 and from mm 7 to 30 in depth. The sliding tracks of the blade holder make possible the shaping of the cut according to the needs required. Due to the simplicity of the mechanics any kind of blade may be used, including ours. the trasformer connected with a signaling light (power on), with a protecting fuse, and three power speed adjustments; They do not fear comparison in power and quality. Extremely practical and light handle.

"CE" approved with electromagnetic compatibility

Tyres

Tyres



360 001 000

Tyre regroover - voltage v.110.
Rigatore per pneumatici - voltaggio v. 110.



360 002 000

Tyre regroover - voltage v.230.
Rigatore per pneumatici - voltaggio v. 230.

TECHNICAL DATA:

Power supply: 220V. or 110V. 50-60 Hz, Monophase
Maximum power absorbed: 400 W
Working handle tension: 1,5 – 2 Volt.
Machine weight: 6,3 Kg.
Power Cable: 220 cm.
Handle Cable: 150 cm.
Cutting width: from 2 mm. to 38 mm.
Cutting depth: from 7 mm. to 30 mm.

Due to the simplicity of the mechanics any kind of blade may be used, including ours. the trasformer connected with a signaling light (power on), with a protecting fuse, and five power speed adjustments; this allows the best choice due to the task.

CARATTERISTICHE TECNICHE: Rigatore per pneumatici.

"CE" approved with electromagnetic compatibility

Tyres

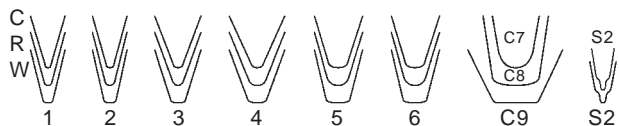

Blades are on request (not included with the machine).

- 360 003 001 Blade type W1
- 360 003 002 Blade type W2
- 360 003 003 Blade type W3
- 360 003 004 Blade type W4
- 360 003 005 Blade type W5
- 360 003 006 Blade type R1
- 360 003 007 Blade type R2
- 360 003 008 Blade type R3
- 360 003 009 Blade type R4
- 360 003 010 Blade type R5
- 360 003 011 Blade type C1
- 360 003 012 Blade type C2
- 360 003 013 Blade type C3
- 360 003 014 Blade type C4
- 360 003 015 Blade type C5
- 360 004 001 Blade type S1
- 360 004 002 Blade type S2
- 360 005 001 Blade type W6
- 360 004 002 Blade type R6
- 360 004 003 Blade type C6
- 360 006 000 Blade type C7
- 360 007 000 Blade type C8
- 360 008 000 Blade type C9

ATTENTION

All cleaning and maintenance operations must be effected with machine disconnected from the net. It is recommended to switch off the machine when stop working.

BLADES TECHNICAL DATA						
SHAPE			Width	Depth*	Thickness	Pieces x each box
Rounded	Angular	Combined				
R1	W1	C1	2-4	7	0.4x3,5	20
R2	W2	C2	4-6	8		20
R3	W3	C3	6-8	10		20
R4	W4	C4	8-10	14	0.6x3,5	20
R5	W5	C5	10-14	16		20
R6	W6	C6	18-22	18		20
		C7	20-26	20	0.6x4	10
		C8	22-28	24		10
		C9	22-38	30		10
Special blades		S1	1	4	0.4x3,5	20
		S2	1	6		20

490 000 000



Air operated motorcycle clamp

Packaging Dimensions: 530 x 610 x 550 mm.

Machine weight: 24 Kg.

Alimentation: Air pressure min 6 bar., max 10 bar

Locking Pressure: 8 bar= 300 Kg., 10 bar=500 Kg.

This machine allows a fast and safe motorcycle repair. The pneumatic cylinder and the special vice shape make possible to lock all types of wheels, from the smallest (scooter) to the biggest (maxi-motorcycles), without damaging the rim. The safety-valves allow to lock and to repair the motorcycles without using any other supports. This machine is equipped also with a drive-valve to adjust the opening and closing speed of the wheel. Applicable to all the types of lifting bridges for motorcycle, it is predisposed for the fixing. With simplicity and safety blocks all the types of motorcycles-wheels.

CE approved machine in compliance with 98/37/CE (Machine Directive)

Motorbike



493 001 000

Cross stand operated by a foot lever. Suitable for cross, trial, Enduro and supermotard bike. Ideal for garages and racetracks. Supplied with a rubber non-slip footboard, it is safety and very stable on every surface.

Cavalletto a pedana per moto da cross, moto enduro e motard. Consente di sollevare la moto con un semplice sistema di leverage a pedale. E' dotato di una pedana in gomma antiscivolo ed offre un sicuro appoggio su ogni tipo di superficie.

Motorbike



493 002 000

Rear single-sided swing arm stand. It is equipped with double wheels and the supporting pin is mounted with a permanently lubricated double bearing.

Cavalletto posteriore per forcelloni monobraccio. E' dotato di doppie ruote per una facile movimentazione. Il perno di ancoraggio è portante e montato su doppi cuscinetti autolubrificanti.

Motorbike





Motorbike

493 003 000

Universal rear stand, with adjustable supports and double wheels. Suitable for all bikes it guarantee maximum stability.

Cavalletto posteriore universale, con sistema basculante a cursori registrabili. Adatto per tutte le moto è dotato di doppie ruote per la massima stabilità.



Motorbike

493 004 000

Universal rear stand supplied with adjustable fork supports and double wheels to guarantee maximum stability.

Cavalletto posteriore con attacchi a "V" dotato di cursori regolabili. E' adatto a tutte le moto predisposte per attacchi con nottolini ed è dotato di doppie ruote per la massima stabilità.



Motorbike

493 005 000

Universal front stand equipped with adjustable supports. Specially designed to be positioned under every kind of forks.

Cavalletto anteriore universale a cursori mobili sottoforcella. La particolare struttura e i coni permettono di evitare le viti passanti all'interno della forcella.



Motorbike

493 006 000

Universal front stand for the handlebar stem. It allows easy removal of the wheel and of the fork rods. It includes different sized pins to fit into the steering stem hole of any bike.

Cavalletto anteriore sottocanotto dotato di doppie ruote. Questo cavalletto consente di sollevare la moto nella parte anteriore lasciando completamente libera la ruota e le forcelle.

GUARANTEE AND PRODUCTS INSURANCE : ALL OUR PRODUCTS ARE COVERED BY A LIABILITY INSURANCE AGAINST ACCIDENTS TO PEOPLE OR THINGS EXTENDED BY A MAJOR EUROPEAN COMPANY, FOR 516.457 EURO. ALL OUR PRODUCTS ARE GUARANTEED AGAINST MANUFACTURING DEFECTS FOR ONE YEAR.

GARANZIA E ASSICURAZIONE PRODOTTI : TUTTI I NOSTRI PRODOTTI SONO COPERTI DA UNA ASSICURAZIONE DI RESPONSABILITA 'CONTRO DANNI A PERSONE E COSE PER 516.457 ,00 EURO. INOLTRE TUTTI I NOSTRI PRODOTTI SONO COPERTI DA GARANZIA CONTRO DIFETTI DI COSTRUZIONE PER UN ANNO.

Le immagini e i dati riportati nelle tabelle sono puramente indicativi e possono essere variati senza preavviso dal costruttore.

Images and specifications included in charts may be subjected to change without prior notice.



OFFICES AND WAREHOUSE: Via degli Orsi, n. 97 - 40014 Loc. Beni Comunali - Crevalcore (BO) Italy
Tel: +39.051.982688 - Tel: +39.051.980798 - Fax: +39.051.6801371 - E-mail: info@govoni.it