





CE

-  Cric idropneumatici per camion
-  **Hydropneumatic heavy duty jacks**
-  Hydropneumatische LKW-Heber
-  Crics hydropneumatiques pour poids lourds
-  Gatos hidro-neumáticos para camión







W136







W135



W123

-  Costruzione robusta per lavoro intensivo • Ruote con cuscinetto a sfera • Valvola limitatrice di carico
-  **Heavy duty design • Wheels with ball bearings • Overload safety valve**
-  Sehr robuste Konstruktion für intensive Arbeiten • Kugelgelagerte Räder • Überlastventil
-  Construction très robuste pour travail intensif • Roulettes avec roulement à billes • Soupape de surcharge
-  Construcción robusta para trabajo pesado • Ruedas con cojinete de bolas • Válvula limitadora de carga



    							
Dati tecnici	Technical data	Technische Eigenschaften	Caractéristiques techniques	Datos técnicos	W136	W135	W123
Portata	Capacity	Capacité	Tragfähigkeit	Capacidad de carga	60/30 t	60/30/18 t	60/30/18 t
Peso	Weight	Poids	Gewicht	Peso	72 kg	47 kg	70 kg
Pressione	Pressure	Pression	Luftdruck	Presión	8 - 12 bar	8 - 12 bar	8 - 12 bar

W136

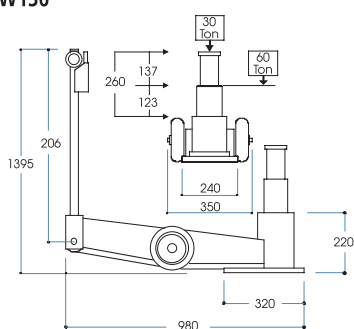

W135

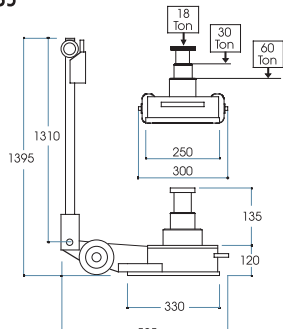

W123

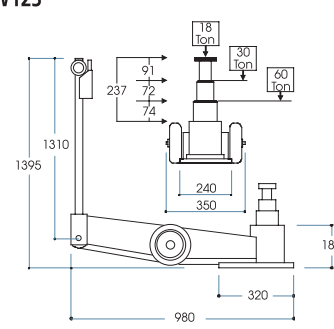

Kit Prolunghe (10,70,120 mm)

Extension kit (10,70,120 mm)

Verlängerungssatz (10,70,120 mm)

Kit de rallonges (10,70,120 mm)

Juego prolongaciones (10, 70, 120 mm)