



ADE Diaphragm Accumulators

For working pressures up to 250 bar

*Catalogue HY07-1248/UK
February 2005*



Why Use a Diaphragm Accumulator?

Liquids are practically incompressible and therefore cannot be used directly for storing energy. Hydro-pneumatic accumulators use the differing compressibility of liquid and gaseous media to enable energy to be stored in liquids under pressure. The upper section of the diaphragm accumulator body contains pressurized gas, isolated from the lower section by a flexible diaphragm. The lower section is connected to the hydraulic system. While system pressure exceeds gas pressure, fluid flows into the accumulator body; when system pressure falls below gas pressure, fluid is discharged back into the hydraulic system, maintaining system pressure and supplementing pump delivery.

Parker's hydro-pneumatic diaphragm accumulators enhance the efficiency of a hydraulic system. Their simple, compact, design ensures dependable performance and long service life in a wide range of industrial and mobile applications.

ADE Series diaphragm accumulators must only be used with a Group 2 fluid. Their use is strictly prohibited with a Group 1 fluid.

Parker's diaphragm accumulators are designed, manufactured and tested to the highest standards. Parker Hannifin does not accept any responsibility for damage to persons or property, or for any consequences, eg: loss of operation, resulting from failure to observe the operating instructions contained in bulletin HY07-1248-T.

European Pressure Equipment Directive

ADE Series accumulators are subjected to conformity assessment procedures in accordance with the European Directive 97/23/EC for pressure equipment. Models with a capacity greater than 1 litre carry the CE mark, while those with a volume up to and including 1 litre are designed and manufactured according to sound engineering practice (SEP).

Features and Benefits

1 Shell

The shell is manufactured from high strength alloy steel. The non-repairable, electron-beam welded construction reduces weight and size, simplifying location and installation.

2 Diaphragm Retaining Ring

The flexible diaphragm is retained by a steel ring, permanently secured during assembly to ensure a gas-tight seal.

3 Diaphragm

The diaphragm provides excellent gas and fluid separation. ADE accumulators are offered with diaphragms in nitrile (NBR) or epichlorohydrine (ECO) compounds; both are suitable for use with mineral oil compounds, while ECO diaphragms provide exceptional low temperature performance for demanding mobile applications.

4 Diaphragm Safety Button

The moulded diaphragm incorporates a 'button' which closes the fluid port when the accumulator is fully discharged, preventing damage which would result from extrusion of the diaphragm into the port.

5 Fluid Port

BSPP port threads are supplied as standard, with other thread forms available to special order – please consult your Parker sales office.

6 Gas Port

The gas port is sealed with a screwed plug, machined to allow the safe release of pressure prior to end-of-life disposal. An external thread enables a Parker UCA charging and gauging kit to be fitted, permitting quick and easy checking and adjustment of the nitrogen pre-charge pressure.

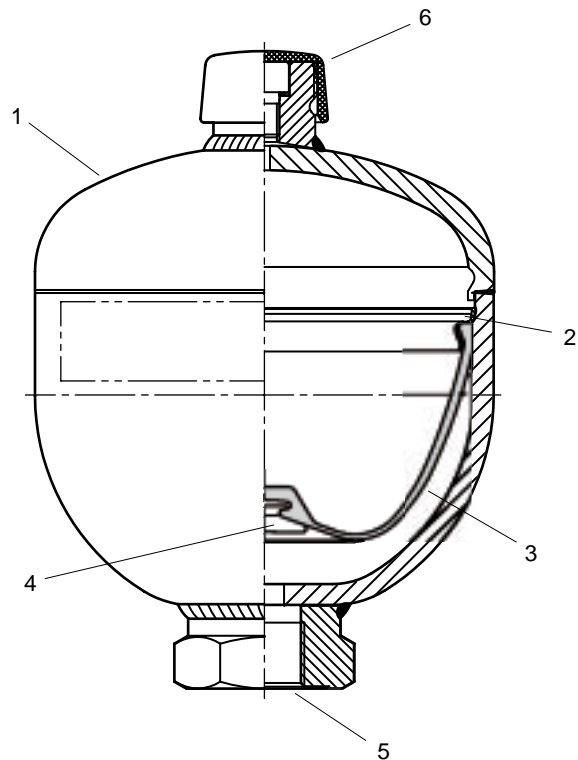

Parker Hannifin Corporation . . .

is a world leader in the manufacture of components and systems for motion control. Parker has more than 800 product lines for hydraulic, pneumatic and electro-mechanical applications in some 1200 industrial and aerospace markets. With over 45,000 employees and some 210 manufacturing plants and administrative offices around the world, Parker provides its customers with technical excellence and first class customer service. Parker Hannifin is the world's largest supplier of hydraulic actuators and accumulators for industrial applications.

Technical Data

Standard volumes 0.075 – 3.5 litres
 Operating pressure Up to 250 bar, depending on model
 Std. temperature range
 Shell and ports: -30°C to +80°C
 Nitrile diaphragm/seals: -10°C to +80°C
 Epichlorohydrine diaphragm/seals: -30°C to +80°C
 Fluid type Mineral oil (standard compounds)

Notes (see Table)

- ¹ A minimum liquid volume (10% of gas volume) must be maintained inside the accumulator.
- ² p_1 is the precharge gas pressure at 20°C.
 p_2 is the maximum working or system pressure.

Flow Rate

The maximum values listed in the table only apply in the case of vertical installation (fluid port facing downwards).

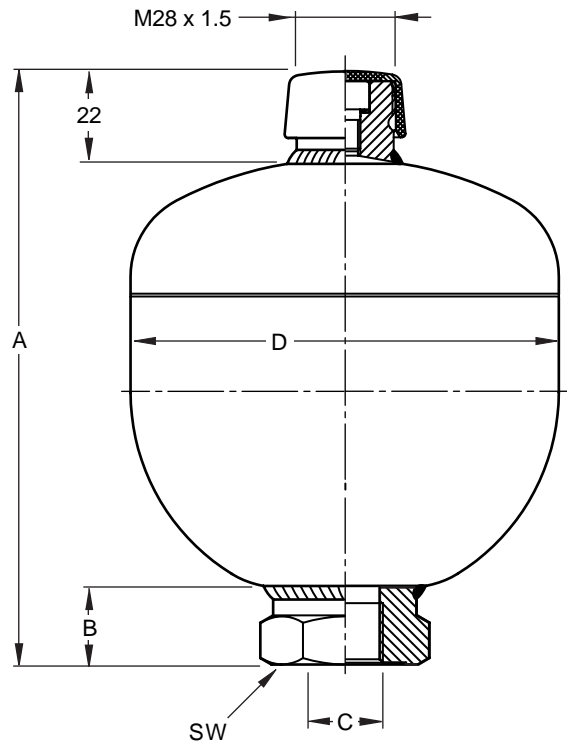

Models, Capacities and Dimensions

Model	Volume Litres	Max. Operating Pressure Bar	Mass Kg	PED 97/23/CE Category	Max Flow ¹ Lpm	Max Pressure Difference Bar	Max Pressure Ratio p_1/p_2 ²	Precharge Pressure ± 5 Bar	A	B	C BSPP	D	SW	Diaphragm Compound
ADE007-25R1A2 ADE007-25R9A2	0.075	250	0.7	–	10	210	1 : 8	60	111	20	G ^{1/2}	64	32	NBR ECO
ADE016-25R1A2 ADE016-25R9A2	0.16	250	1.0	–		210	1 : 6		75			NBR ECO		
ADE032-21R1A2 ADE032-21R9A2	0.32	210	1.3	–	140	1 : 8	40	134	93			NBR ECO		
ADE050-21R1A2 ADE050-21R9A2	0.5	210	2.0	–	175			163	106	NBR ECO				
ADE075-21R1A2 ADE075-21R9A2	0.75	210	3.7	–	175			167	122	NBR ECO				
ADE100-21R1A2 ADE100-21R9A2	1.0	210	3.5	–	40	170	1 : 8	180	22	G ^{1/2}	136	41	NBR ECO	
ADE140-14R1C2 ADE140-14R9C2	1.4	140	4.2	I		120					191		147	NBR ECO
ADE140-25R1C2 ADE140-25R9C2	1.4	250	6.0	II		140					198		155	NBR ECO
ADE200-25R1C2 ADE200-25R9C2	2.0	250	7.5	II	60	140	1 : 4	251	21	G ^{3/4}	155	174	NBR ECO	
ADE280-25R1C2 ADE280-25R9C2	2.8	250	10	II		140					268		174	NBR ECO
ADE350-25R1C2	3.5	250	11	II		140					307		174	NBR

All dimensions are in millimetres unless otherwise stated.

In line with our policy of continuing product improvement, specifications in this catalogue are subject to change without notice.

Hydraulics Group Sales Offices

Europe

Austria

Wiener Neustadt
Tel: +43 (0)2622 23501
Fax: +43 (0)2622 66212

Belgium

Nivelles
Tel: +32 (0)67 280 900
Fax: +32 (0)67 280 999

Czech Republic

Klecany
Tel: +420 284 083 111
Fax: +420 284 083 112

Denmark

Ballerup
Tel: +45 4356 0400
Fax: +45 4373 8431

Finland

Vantaa
Tel: +358 (0)9 4767 31
Fax: +358 (0)9 4767 3200

France

Contamine-sur-Arve
Tel: +33 (0)450 25 80 25
Fax: +33 (0)450 03 67 37

Germany

Kaarst
Tel: +49 (0)2131 4016 0
Fax: +49 (0)2131 4016 9199

Hungary

Budapest
Tel: +36 (06)1 220 4155
Fax: +36 (06)1 422 1525

Ireland

Dublin
Tel: +353 (0)1 293 9999
Fax: +353 (0)1 293 9900

Italy

Corsico (MI)
Tel: +39 02 45 19 21
Fax: +39 02 4 47 93 40

The Netherlands

Oldenzaal
Tel: +31 (0)541 585000
Fax: +31 (0)541 585459

Norway

Ski
Tel: +47 64 91 10 00
Fax: +47 64 91 10 90

Poland

Warsaw
Tel: +48 (0)22 863 49 42
Fax: +48 (0)22 863 49 44

Portugal

Leca da Palmeira
Tel: +351 22 9997 360
Fax: +351 22 9961 527

Slovakia

Ref. Czech Republic

Spain

Madrid
Tel: +34 91 675 73 00
Fax: +34 91 675 77 11

Sweden

Spånga
Tel: +46 (0)8 597 950 00
Fax: +46 (0)8 597 951 10

Turkey

Merter/Istanbul
Tel.: +90 212 482 91 06 or 07
Fax: +90 212 482 91 10

United Kingdom

Warwick
Tel: +44 (0)1926 317 878
Fax: +44 (0)1926 317 855

International

Australia

Castle Hill
Tel: +61 (0)2-9634 7777
Fax: +61 (0)2-9899 6184

Canada

Milton, Ontario
Tel: +1 905-693-3000
Fax: +1 905-876-0788

China

Beijing
Tel: +86 10 6561 0520
Fax: +86 10 6561 0526

Asia Pacific Group

Hong Kong, Kowloon
Tel: +852 2428 8008
Fax: +852 2425 6896

India

Mumbai
Tel: +91 22 7907081
Fax: +91 22 7907080

Japan

Tokyo
Tel: +(81) 3 6408 3900
Fax: +(81) 3 5449 7201

Latin America Group

Brazil
Tel: +55 12 3954-5100
Fax: +55 12 3954-5266

South Africa

Kempton Park
Tel: +27 (0)11-961 0700
Fax: +27 (0)11-392 7213

USA

Cleveland (industrial)
Tel: +1 216-896-3000
Fax: +1 216-896-4031
Lincolnshire (mobile)
Tel: +1 847-821-1500
Fax: +1 847-821-7600

Parker Hannifin is the world's premier supplier of motion and control systems and solutions, with sales and manufacturing facilities throughout the world. For product information and details of your nearest Parker sales office, visit us at www.parker.com or call free on 00800 2727 5374.



Catalogue HY07-1248/1-UK
2M 02/05 CQ

© Copyright 2005
Parker Hannifin Corporation
All rights reserved.