

Workbenches

1505 MOBILE WORKBENCH

Body:

- > Dimensions: H 900 x W 1100 x D 652 mm
- > 40 mm thick multiplex beech wood worktop, surface additionally protected by linseed oil varnish
- > Large usable storage space with shelf and door
- > Easy, safe movement with pull handle
- > Heel protection for your safety
- > Sheet steel, corrosion resistant and scratch-proof powder-coated, GEDORE blue

Drawers:

- > Central locking with cylinder lock
- > 5 wide drawers (W 480 x D 550 mm), extendable up to 505 mm, removable
- > Each drawer with safety locking, single-hand operation
- > Ball-bearing guide rails
- > Can be individually equipped with lengthwise and crosswise dividers (can be ordered individually)
- > Load capacity per drawer 40 kg
- > Sheet steel, corrosion resistant and scratch-proof powder-coated, GEDORE blue

GEDORE Jumbo heavy-duty chassis:

- > Total load capacity 2000 kg, 500 kg when mobile
- > 4 GEDORE wheels on roller bearings with independent wheel suspension
- > Absolutely stable standing when lowered
- > Mobile due to hydraulic raising mechanism, just lift the pull handle
- > High floor clearance

Accessories:

- > 9 length- (LT) and 9 crosswise (QT) dividers from zinc-plated sheet steel

Options:

- > Can be equipped with GEDORE tool modules (1500 ES/1500 CT)
- > Rear panel R 1504 L can be added
- > Delivery without tools and accessories
- > Special colours and designs available on request

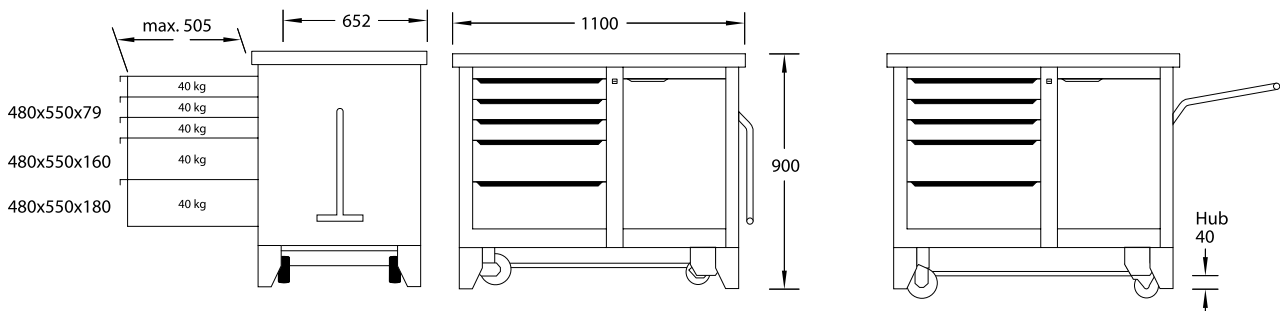

Description	H	W	D	mm	LD	CD	kg	Code	No.
Mobile workbench	900	1100	652	40	9x	9x	138.0	6621780	1505
Mobile workbench with vice	900	1100	652	40	9x	9x	156.5	6621860	1505 S

R 1504 XL-L



>34

411



>554



1506 XL MOBILE WORKBENCH EXTRA WIDTH

Body:

- > Dimensions: H 985 x W 1250 x D 550 mm
- > 30 mm thick multiplex beech wood worktop, surface additionally protected by linseed oil varnish
- > With two similar drawer blocks
- > Heel protection for your safety
- > Sheet steel, corrosion resistant and scratch-proof powder-coated, GEDORE blue

Drawers:

- > Central locking with cylinder lock
- > Wide drawers (W 480 x D 400 mm) fully extendable, removable
- > Each drawer with safety locking, single-hand operation
- > Ball-bearing guide rails
- > Can be individually equipped with lengthwise and crosswise dividers (can be ordered individually)
- > Load capacity per drawer 40 kg, bottom heavy-duty drawers 60 kg
- > Sheet steel, corrosion resistant and scratch-proof powder-coated, GEDORE blue

GEDORE High-performance chassis:

- > Total load capacity 700 kg, 500 kg when mobile
- > 2 high-performance wheels on roller bearings (fixed castors Ø 200 mm)
- > 2 smooth running wheels on ball bearings (swivel castors Ø 125 mm), both with total brake
- > The GEDORE trapezoidal axle construction secures smooth running, manoeuvrability and track-keeping also in case of maximum loads

Accessories:

- > 4 distance modules No. 1500 ED-70 K
- > Length- (LT) and crosswise (QT) dividers from zinc-plated sheet steel

Options:

- > Can be equipped with GEDORE tool modules (1500 ES/1500 CT)
- > Rear panel R 1504 XL-L can be added
- > Further drawer combinations on request
- > Special colours and designs available on request
- > Delivery without tools and accessories



1506 XL VARIANTS



No.	1506 XL 2511	1506 XL 2810
	14 drawers: 10x type 1, H = 67 mm 2x type 2, H = 137 mm 2x type 3, H = 207 mm	18 drawers: 16x type 1, H = 67 mm 2x type 2, H = 137 mm
H	985	985
W	1250	1250
D	550	550
mm	30	30
LD	15x	15x
CD	3x	3x
	140.0	150.0
Code	2528088	2528096

1506 XL 2511

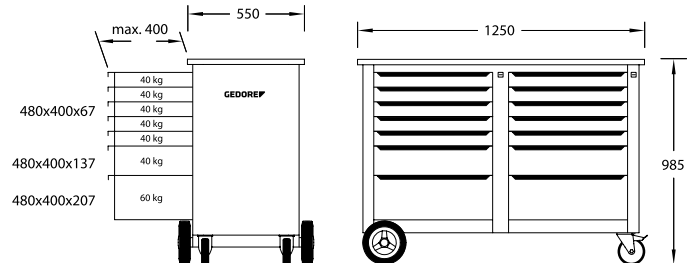

1506 XL 2810

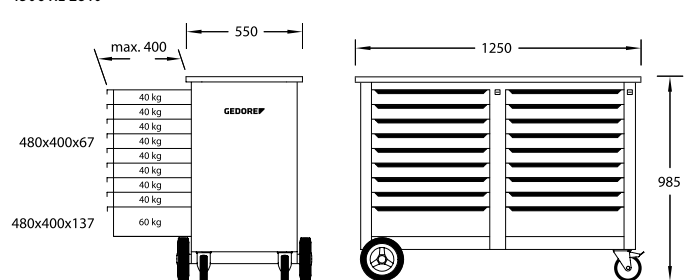

1504 MOBILE WORKBENCH

Body:

- > Dimensions: H 985 x W 1100 x D 550 mm
- > 30 mm thick multiplex beech wood worktop, surface additionally protected by linseed oil varnish
- > Large storage space with shelf and door
- > Heel protection for your safety
- > Sheet steel, corrosion resistant and scratch-proof powder-coated, GEDORE blue

Drawers:

- > Central locking with cylinder lock
- > Wide drawers (W 480 x D 400 mm) fully extendable, removable
- > Each drawer with safety locking, single-hand operation
- > Ball-bearing guide rails
- > Can be individually equipped with lengthwise and crosswise dividers (can be ordered individually)
- > Load capacity per drawer 40 kg, bottom heavy-duty drawer 60 kg (apart from no. 1504 1000)
- > Sheet steel, corrosion resistant and scratch-proof powder-coated, GEDORE blue

GEDORE High-performance chassis:

- > Total load capacity 700 kg, 500 kg when mobile
- > 2 high-performance wheels on roller bearings (fixed castors Ø 200 mm)
- > 2 smooth running wheels on ball bearings (swivel castors Ø 125 mm), both with total brake
- > The GEDORE trapezoidal axle construction secures smooth running, manoeuvrability and track-keeping also in case of maximum loads

Accessories:

- > 4 distance modules no. 1500 ED-70 K
- > Length- (LT) and crosswise (QT) dividers from zinc-plated sheet steel

Options:

- > Can be equipped with GEDORE tool modules (1500 ES/1500 CT)
- > Rear panel no. R 1504 L or RT 1504 L can be added
- > Further drawer combinations on request
- > Special colours and designs available on request
- > Delivery without tools and accessories

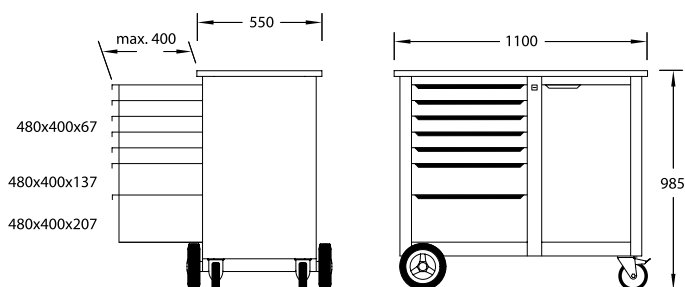



1504 VARIANTS



Code	6622830	6623050	1814958
	7 drawers: 5x type 1, H = 67 mm 1x type 2, H = 137 mm 1x type 3, H = 207 mm	7 drawers: 5x type 1, H = 67 mm 1x type 2, H = 137 mm 1x type 3, H = 207 mm	6 drawers: 3x type 1, H = 67 mm 2x type 2, H = 137 mm 1x type 3, H = 207 mm
Description	Mobile workbench with 7 drawers	Mobile workbench with 7 drawers and vice	Mobile workbench with 6 drawers
H	985	985	985
W	1100	1100	1100
D	550	550	550
LD	10x	10x	6x
CD	2x	2x	2x
	103.0	112.5	96.0
No.	1504 0511	1504 0511 S	1504 0321



Code	1814931	1814923	1814915
	8 drawers: 7x type 1, H = 67 mm 1x type 3, H = 207 mm	9 drawers: 8x type 1, H = 67 mm 1x type 2, H = 137 mm	10 drawers: 10x type 1, H = 67 mm
Description	Mobile workbench with 8 drawers	Mobile workbench with 9 drawers	Mobile workbench with 10 drawers
H	985	985	985
W	1100	1100	1100
D	550	550	550
LD	10x	15x	15x
CD	2x	3x	3x
	99.0	106.0	110.0
No.	1504 0701	1504 0810	1504 1000

1504 0511 + 1504 0511 S

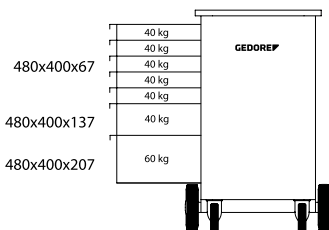

1504 0321

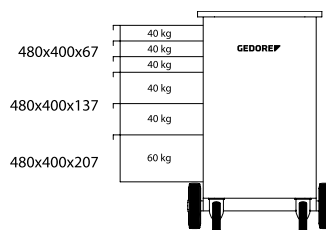

1504 0701

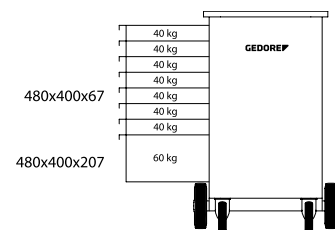

1504 0810

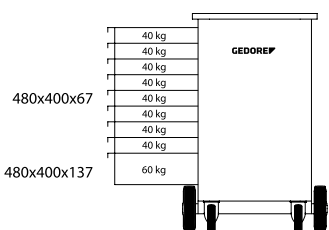

1504 1000

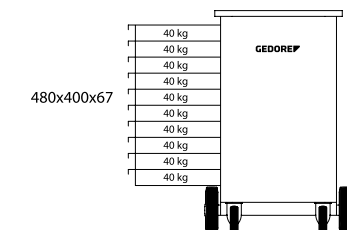

1504 XL

MOBILE WORKBENCH EXTRA WIDTH

Body:

- > Dimensions: H 985 x W 1250 x D 550 mm
- > 30 mm thick multiplex beech wood worktop, surface additionally protected by linseed oil varnish
- > Large usable storage space with shelf and door
- > Heel protection for your safety
- > Sheet steel, corrosion resistant and scratch-proof powder-coated, GEDORE blue

Drawers:

- > Central locking with cylinder lock
- > 1 XL drawer (W 1055 x D 400), 6 wide drawers (W 640 x D 400 mm) fully extendable, removable
- > Each drawer with safety locking, single-hand operation
- > Ball-bearing guide rails
- > Can be individually equipped with lengthwise and crosswise dividers (can be ordered individually)
- > Load capacity per drawer 40 kg, bottom heavy-duty drawer 60 kg
- > Sheet steel, corrosion resistant and scratch-proof powder-coated, GEDORE blue

GEDORE High-performance chassis:

- > Total load capacity 700 kg, 500 kg when mobile
- > 2 high-performance wheels on roller bearings (fixed castors Ø 200 mm)
- > 2 smooth running wheels on ball bearings (swivel castors Ø 125 mm), both with total brake
- > The GEDORE trapezoidal axle construction secures smooth running, manoeuvrability and track-keeping also in case of maximum loads

Accessories:

- > 10 length- (LT) and 2 crosswise (QT) dividers from zinc-plated sheet steel

Options:

- > Can be equipped with GEDORE tool modules (1500 ES/1500 CT or 2005 CT)
- > Rear panel R 1504 XL-L can be added
- > Further drawer combinations on request
- > Special colours and designs available on request
- > Delivery without tools and accessories



H	W	D	mm	kg	Code	No.
985	1250	550	30	120.0	1988468	1504 XL

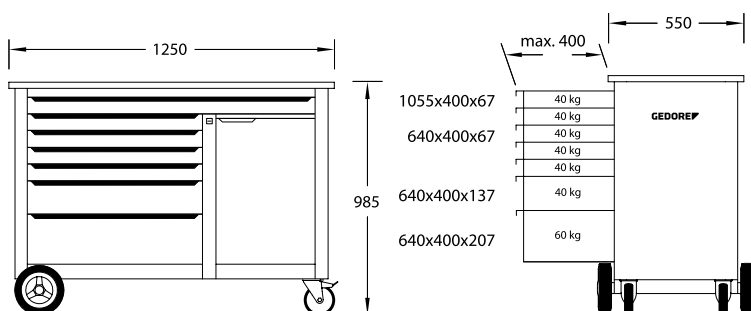



BR 1504 MOBILE WORKBENCH

with self raising rear panel

Body:

- > Dimensions: H 985 x W 1100 x D 550 mm
- > 30 mm thick multiplex beech wood worktop, surface additionally protected by linseed oil varnish
- > Large usable storage space with shelf and door
- > With rear panel, square perforation 10 x 38 mm to fix hooks and tools, with lowering mechanism, can be raised by 2 gas springs
- > Heel protection for your safety
- > Sheet steel, corrosion resistant and scratch-proof powder-coated, GEDORE blue

Drawers:

- > Central locking with cylinder lock
- > Wide drawers (W 480 x D 400 mm) fully extendable, removable
- > Each drawer with safety locking, single-hand operation
- > Ball-bearing guide rails
- > Can be individually equipped with lengthwise and crosswise dividers (can be ordered individually)
- > Load capacity per drawer 40 kg, bottom heavy-duty drawer 60 kg
- > Sheet steel, corrosion resistant and scratch-proof powder-coated, GEDORE blue

GEDORE High-performance chassis:

- > Total load capacity 700 kg, 500 kg when mobile
- > 2 high-performance wheels on roller bearings (fixed castors Ø 200 mm)
- > 2 smooth running wheels on ball bearings (swivel castors Ø 125 mm), both with total brake
- > The GEDORE trapezoidal axle construction secures smooth running, manoeuvrability and track-keeping also in case of maximum loads

Accessories:

- > 2 distance modules No. 1500 ED-70 K
- > 10 length- (LT) and 2 crosswise (QT) dividers from zinc-plated sheet steel

Options:

- > Can be equipped with GEDORE tool modules (1500 ES/1500 CT)
- > Further drawer combinations on request
- > Special colours and designs available on request
- > Delivery without tools and accessories

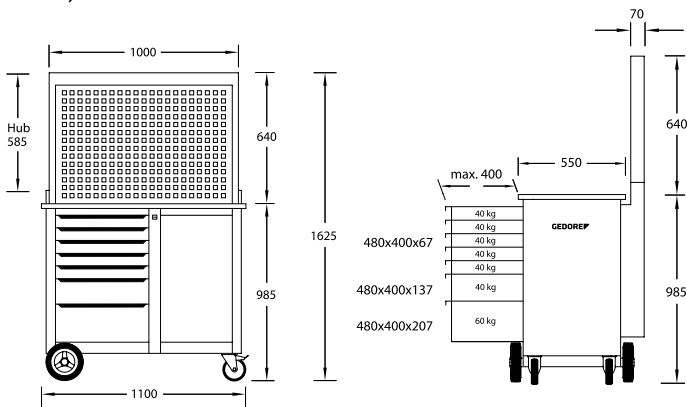

Description	H	W	D	mm	LD	CD	mm	Code	No.
Workbench with rear panel	985	1100	550	30	10x	2x	128.0	6624450	BR 1504 0511 L
Workbench with rear panel + hook assortment	985	1100	550	30	10x	2x	130.0	6623990	BR 1504 0511 LH
Workbench with rear panel + vice	985	1100	550	30	10x	2x	142.5	6624370	BR 1504 0511 S

411 >554

1500 ES / 1500 CT >98/105

BR 1500 LH WORKBENCH WITH TOOL CABINET

Body workbench:

- > Dimensions: H 900 x W 2000 x D 875 mm
- > 40 mm thick multiplex beech wood worktop, surface additionally protected by linseed oil varnish
- > Large storage space with shutter
- > Heel protection for your safety
- > Sheet steel, corrosion resistant and scratch-proof powder-coated, GEDORE blue

Body cabinet:

- > Dimensions: H 890 x W 1810 x D 170 mm
- > Shutter with cylinder lock
- > Rear panel with square perforation 10 x 38 mm to fix hooks and tools
- > Sheet steel, corrosion resistant and scratch-proof powder-coated, GEDORE blue
- > Shutter from sheet steel, corrosion resistant and scratch-proof powder-coated, GEDORE blue

Drawers workbench:

- > Separate central locking of drawers and shutter with cylinder locks
- > 5 wide drawers (W 480 x D 550 mm), extendable up to 505 mm, removeable
- > Ball-bearing guide rails
- > Can be individually equipped with lengthwise and crosswise dividers (can be ordered individually)
- > Load capacity per drawer 40 kg
- > Sheet steel, corrosion resistant and scratch-proof powder-coated, GEDORE blue
- > Total load capacity (workbench) 2000 kg

Accessories:

- > 85-piece hook assortment 1500 HS 23
- > 9 length- (LT) and 9 crosswise (QT) dividers from zinc-plated sheet steel

Options:

- > Can be equipped with GEDORE tool modules (1500 ES/1500 CT)
- > Special colours and designs available on request
- > Delivery without tools and accessories

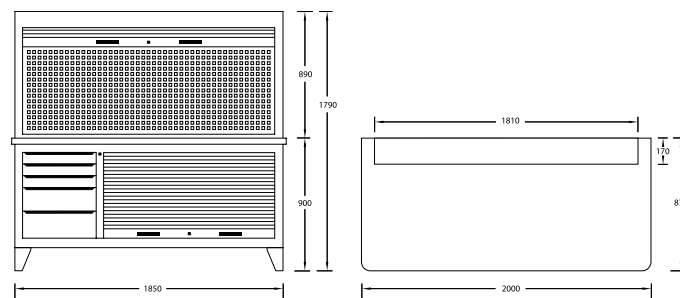
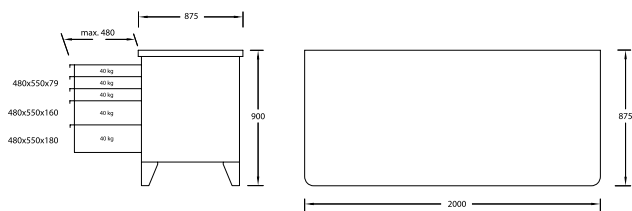

BR 1500 VARIANTS



No.	BR 1500 LH	B 1500 L	R 1500 L
Description	Workbench with tool cabinet	Workbench without tool cabinet	Tool cabinet with blind, empty
H	1790	900	890
W	2000	2000	1810
D	875	875	170
mm	40	40	
LD	9x	9x	
CD	9x	9x	
kg	203.7	166.0	78.0
Code	6618210	6618050	6617910



1502

MOBILE WORKBENCH

Body:

- > Dimensions: H 875 x W 950 x D 550 mm
- > 25 mm thick multiplex beech wood worktop, surface additionally protected by linseed oil varnish
- > Large, easily-accessible spaces for bulky parts
- > Heel protection for your safety
- > Sheet steel, corrosion resistant and scratch-proof powder-coated, GEDORE blue

Drawers:

- > Central locking with cylinder lock
- > 6 wide drawers (W 480 x D 400 mm) fully extendable, removable
- > Each drawer with safety locking, single-hand operation
- > Ball-bearing guide rails
- > Can be individually equipped with lengthwise and crosswise dividers (can be ordered individually)
- > Load capacity per drawer 40 kg, bottom heavy-duty drawer 60 kg
- > Sheet steel, corrosion resistant and scratch-proof powder-coated, GEDORE blue

GEDORE High-performance chassis:

- > Total load capacity 700 kg, 500 kg when mobile
- > 2 high-performance wheels on roller bearings (fixed castors Ø 200 mm)
- > 2 smooth running wheels on ball bearings (swivel castors Ø 125 mm), both with total brake
- > The GEDORE trapezoidal axle construction secures smooth running, manoeuvrability and track-keeping also in case of maximum loads

Accessories:

- > 2 distance modules No. 1500 ED-70 K
- > 10 length- (LT) and 2 crosswise (QT) dividers from zinc-plated sheet steel

Options:

- > Can be equipped with GEDORE tool modules (1500 ES/1500 CT)
- > Special colours and designs available on request
- > Delivery without tools and accessories

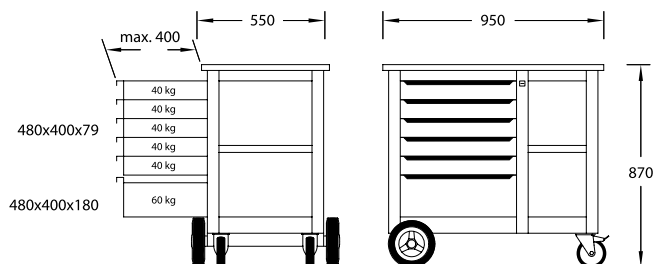

Description	H	W	D	mm	LD	CD		Code	No.
Mobile workbench	870	950	550	25	10x	2x	78.0	6620540	1502
Mobile workbench with vice	870	950	550	25	10x	2x	85.0	6620620	1502 S

Folding workbench

B 1525 FOLDING WORKBENCH

Body:

- > Dimensions: H 810/140 x W 1000 x D 700 mm
- > Strong beech wood worktop with zinc-plated steel edge protector - corrosion resistant
- > Stable folding, space-saving and mobile

GEDORE Base:

- > Total load capacity 500 kg
- > Steel tube, corrosion resistant and scratch-proof powder-coated, GEDORE blue
- > Delivery without tools and accessories

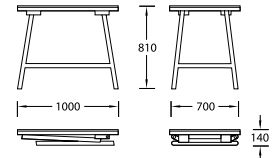

H	W	D	mm	kg	Code	No.
810	1000	700	30	32.0	6622910	B 1525

Accessories for Workbenches

R 1504 L REAR PANEL

- > Can be attached to workbench 1504 or 1505
- > Automatically raised by two gas springs, lockable with cylinder lock
- > Neat arrangement of tools
- > Square perforation 10 x 38 mm
- > Dimensions: H 640 x W 1000 x D 70 mm
- > GEDORE blue
- > Execution LH with hook assortment No. 1504 HS

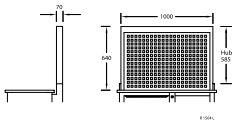

Description	H	W	D	kg	Code	No.
Rear panel empty	640	1000	70	28.0	6623800	R 1504 L
Rear panel empty with hook assortment	640	1000	70	30.0	6624020	R 1504 LH

R 1504 XL-L REAR PANEL

- > Can be attached to workbench 1504 XL, 1506 XL
- > Automatically raised by two gas springs, lockable with cylinder lock
- > Neat arrangement of tools
- > Square perforation 10 x 38 mm
- > Dimensions: H 640 x W 1190 x D 70 mm
- > GEDORE blue
- > Execution LH with hook assortment No. 1504 HS



Description	H	W	D	kg	Code	No.
Rear panel empty	640	1190	70	29.0	2251787	R 1504 XL-L
Rear panel empty with hook assortment	640	1190	70	31.0	2251795	R 1504 XL-LH

RT 1504 L REAR PANEL BOARD

- > Can be attached to workbenches 1504 and 1505
- > Square perforation 10 x 38 mm
- > GEDORE blue
- > Including attachment material



H	W	D	kg	Code	No.
715	1025	30	5.0	2477025	RT 1504 L

Accessories Tool Trolleys / Workbenches

1500 H 13
ANTI-SLIP MAT

Products sold by the metre

- > For all drawers in GEDORE tool trolleys and workbenches
- > Various areas of application: Workshop, household, car, spare time...
- > Enormous slip resistance on many different surfaces
- > Can be cut to size
- > Resistant to temperatures from -30 °C to +100 °C
- > Melting point approx. +250 °C
- > Flame resistant
- > Resistant to chemicals
- > Shock- and noise absorbing
- > Dimensions: W 475 x L 2000 mm



L m	W		Code	No.
2	475	0.540	5790250	1500 H 13

Drawer Partitions

E-1500 - E-2500
LENGTHWISE DIVIDER

slotted

- > In two different heights
- > In five different lengths for varying drawer depths
- > In zinc-plated sheet steel



H	L	for use with		Code	No.
42	317	1580	0.136	5325840	E-1580/14
60	320	1430	0.190	5326570	E-2500/62
60	395	2005, 1504 XL (type 1), 1506 XL (type 1), 2430	0.235	1886932	E-2005 KL/42
60	397	1502 (1-5), 1504 (1-6), 2004 (type 1)	0.208	5326490	E-1504 KL/57
60	548	B 1500 (1-3), 1505 (1-3)	0.312	5315880	E-B 1500/38

E-2005 CT
LENGTHWISE DIVIDER

without slots

- > To fix the modules 2005 CT2

H		Code	No.
40	0.248	2104601	E-2005 CT H-40

E-1580
CROSSWISE DIVIDER

- > Usage: 1580
- > In three different lengths, to fit the lengthwise dividers
- > In zinc-plated sheet steel



E-1580/11-40

L	H		Code	No.
40	40	0.012	1394878	E-1580/11-40
80	40	0.024	5325760	E-1580/11-80
120	40	0.036	5326140	E-1580/11-120

E-3000
CROSSWISE DIVIDER

- > Usage: 1430, B 1500 (1-3), 1502 (1-5), 1504 (1-6), 1504 XL, 1505 (1-3), 1506 XL (type 1), 2004 (type 1), 2005 (type 1), 2430
- > In zinc-plated sheet steel



L	H		Code	No.
80	55	0.035	5326060	E-3000/37-80
120	55	0.050	5326220	E-3000/37-120



Suitable for perforated panels with square perforation 10 x 38 mm

1500 HS-1016	1500 HS-1000	1500 HS-1002	1500 HS-1400 GA	1500 HS-1005 A	1500 HS-1008	1500 HS-1151	1500 HS-1007	1500 HS-1400 Z	1500 HS-1093	1500 HS-1004	1500 HS-1092	1500 HS-1050	1500 HS-1024	1500 HS-1151 A	1500 HS-1091	1500 HS-1025
2656922	2656930	2656949	2656957	2656965	2656973	2656981	2657015	2657023	2657031	2657058	2657066	2657074	2657082	2657090	2657104	265711
0,845	1,109	4,526		1,985	9,087	1,662	6,215	0,907	0,817	1,927		0,996	1,887	1,620		0,908
	6	1	18	5	20	4	19	3	9	13	9	5	16	5	12	8
18	15	31	17	19	27	13	44	4	8	28	12	10	26	19	6	16
6	2	16		9	10	1	13	6	1	6		2	3	1	1	1
	5	6	6	12	7	5	7	7	2	6	1	1	11	5	1	4
					7		3									
	4	8	7	8	3	9	7	8		4	2	2	2	2		1
	9	15	19	23	21	13	23	1	2	20	1		6	15		
			24	1	3	1	1							1		
3	3	6	5	4	9	3	14	1	4	5	2	2	4	3	3	1
		8	14			1								1		

